

City of Surrey
PLANNING & DEVELOPMENT REPORT

File: 7915-0185-00

Planning Report Date: June 12, 2017

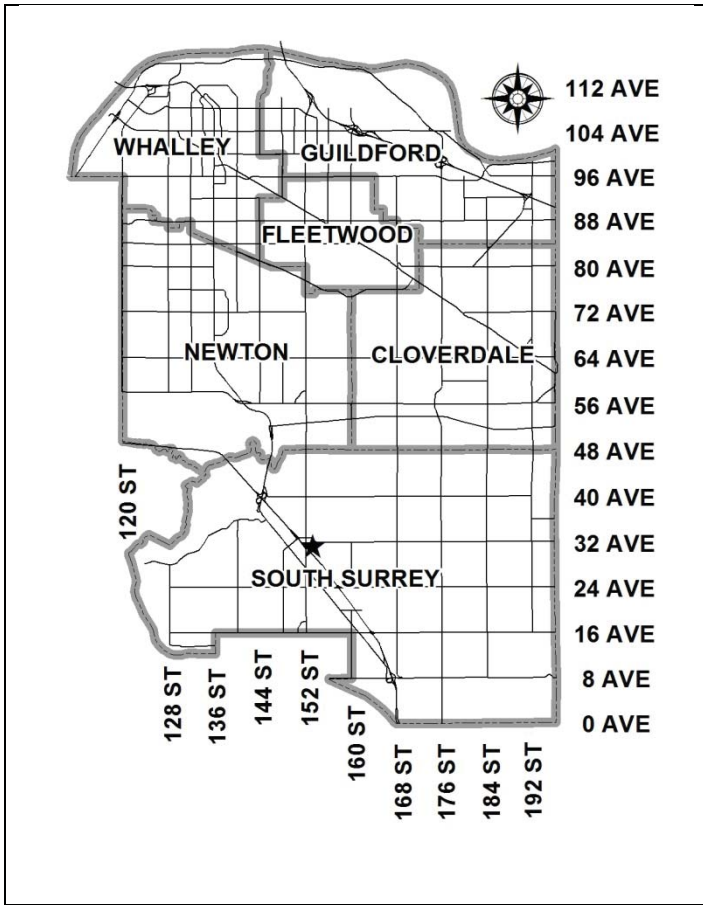

PROPOSAL:

- **OCP Amendment** for a portion from "Urban" to "Mixed Employment"
- **Rezoning** from RA and IB to CD (based on IB-3)
- **Development Permit**
- **Development Variance Permit**

to permit the development of a two-storey multi-tenant business park building and a future three-storey business park building.

LOCATION: 3032 - Croydon Drive
 3035 - 156 Street

OWNER: Rosemary Business Park Ltd.
 City of Surrey

ZONING: RA and IB

OCP DESIGNATION: Mixed Employment and Urban

NCP DESIGNATION: Business Park and Creek
 Preservation Areas

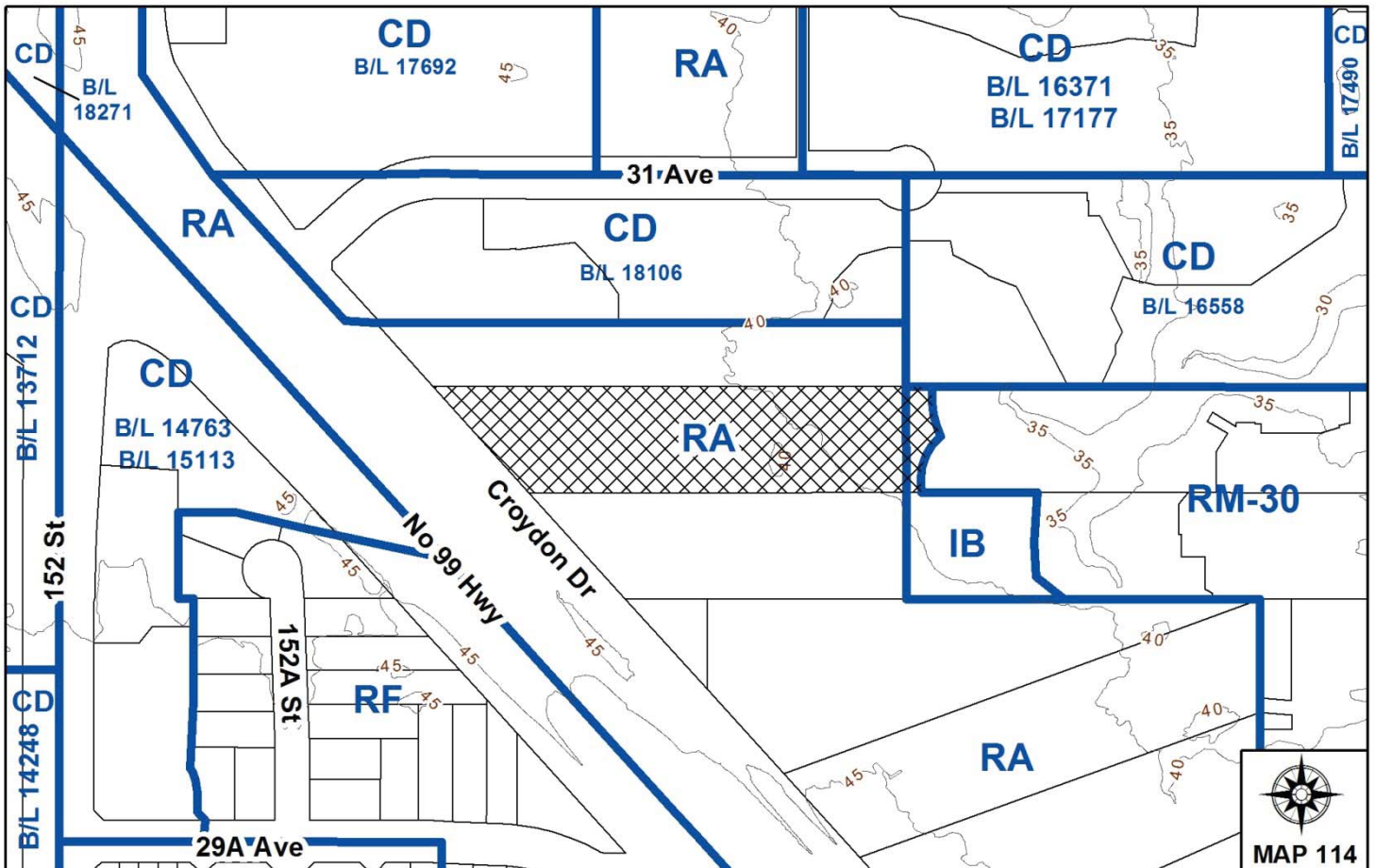

RECOMMENDATION SUMMARY

- By-law Introduction and set date for Public Hearing for:
 - OCP Amendment; and
 - Rezoning.
- Approval to draft a detailed Development Permit for a two-storey multi-tenant building proposed along Croydon Drive (Building 1).
- Approval to draft a General Development Permit for a three-storey multi-tenant building that will be located at the rear of the subject site proposed as part of a future phase of development (Building 2).
- Approval for Development Variance Permit to proceed to Public Notification.

DEVIATION FROM PLANS, POLICIES OR REGULATIONS

- Proposed amendment to the Official Community Plan (OCP) from "Urban" to "Mixed Employment" for the westerly portion of 3035 – 156 Street (Appendix VI).
- Proposed variance to reduce the minimum setback requirement from top-of-bank for a Class B watercourse.

RATIONALE OF RECOMMENDATION

- An OCP Amendment is required to achieve the proposed land-use and to facilitate consolidation of the subject property located at 3032 Croydon Drive, designated "Mixed Employment" in the OCP, with the westerly portion of 3035 – 156 Street, currently designated "Urban" in the OCP.
- The proposal complies with the "Business Park" designation in the Rosemary Heights Business Park Neighbourhood Concept Plan (NCP).
- A General Development Permit (DP) is required to facilitate the development of a future business park building (Building 2) that is proposed in a future phase of development. The General DP sets out the general guidelines that will help to ensure a high-quality development is achieved and, specifically, sets out proposed site access, parking requirements, density and building form. The applicant is required to submit a separate detailed DP application for Building 2, based on the General DP, when the rear portion of the subject property redevelops.
- The proposal is consistent with the conceptual site design for business park development located adjacent to the B.C. Hydro corridor in the Rosemary Heights Business Park NCP (Appendix VIII).
- The development application was in process prior to Council having adopted changes to the Zoning By-law and Official Community Plan (OCP) that allow for the protection of riparian areas under Part 7A Streamside Protection of the Zoning By-law and through the Development Permit Guidelines in the OCP for Sensitive Ecosystems.

RECOMMENDATION

The Planning & Development Department recommends that:

1. an OCP Amendment By-law be introduced to:
 - (a) amend "Figure 3: General Land Use Designations" by re-designating a portion of the subject property at 3035 – 156 Street from Urban to Mixed Employment; and
 - (b) amend "Figure 42: Major Employment Areas" by adding the Mixed Employment designation to a portion of the subject property at 3035 – 156 Street;and a date be set for Public Hearing.
2. Council determine the opportunities for consultation with persons, organizations and authorities that are considered to be affected by the proposed amendment to the Official Community Plan, as described in the Report, to be appropriate to meet the requirement of Section 475 of the Local Government Act.
3. a By-law be introduced to:
 - (a) rezone the subject site at 3032 Croydon Drive from "One-Acre Residential Zone (RA)" to "Comprehensive Development Zone (CD)"; and
 - (b) rezone a portion of the subject site at 3035 – 156 Street, shown as Block B, on the attached Survey Plan (Appendix I) from "Business Park Zone (IB)" to "Comprehensive Development Zone (CD)";and a date for Public Hearing be set.
4. Council authorize staff to draft Development Permit No. 7915-0185-00 for the following:
 - (a) Form and Character; and
 - (b) Sensitive Ecosystems;generally in accordance with the attached drawings (Appendix II).
5. Council approve Development Variance Permit No. 7915-0185-00 (Appendix V), to reduce the minimum setback requirement from the top-of-bank for a Class B watercourse from 15 metres (49 ft.) to 10 metres (33 ft.), at the closest point, to accommodate the proposed development, to proceed to Public Notification.
6. Council instruct staff to resolve the following issues prior to final adoption:
 - (a) ensure that all engineering requirements and issues including restrictive covenants, dedications, and rights-of-way where necessary, are addressed to the satisfaction of the General Manager, Engineering;
 - (b) submission of a subdivision layout to the satisfaction of the Approving Officer;

- (c) successful acquisition of the westerly portion of 3035 – 156 Street;
- (d) final approval from the Ministry of Transportation & Infrastructure;
- (e) final approval from B.C. Hydro;
- (f) submission of a finalized tree survey and a statement regarding tree preservation to the satisfaction of the City Landscape Architect;
- (g) submission of a landscaping plan and landscaping cost estimate to the specifications and satisfaction of the Planning and Development Department;
- (h) the applicant satisfy the deficiency in tree replacement on the site, to the specifications and satisfaction of the Planning and Development Department;
- (i) demolition of existing buildings and structures to the satisfaction of the Planning and Development Department;
- (j) resolution of all urban design issues to the satisfaction of the Planning and Development Department;
- (k) registration of a Section 219 Restrictive Covenant to adequately address the City's needs with respect to public art, to the satisfaction of the General Manager Parks, Recreation and Culture;
- (l) discharge of Restrictive Covenant BE1497713 on 3035 – 156 Street which prohibits the submission of a Development Permit application on the lands until adequate works and services are available; and
- (m) completion of a Sensitive Ecosystem Development Permit to the satisfaction of the General Manager, Planning & Development Department.

REFERRALS

Engineering:	The Engineering Department has no objection to the project subject to the completion of Engineering servicing requirements as outlined in Appendix III.
Parks, Recreation & Culture:	A P-15 agreement is required for the monitoring and maintenance of the conveyed riparian area.
Ministry of Transportation & Infrastructure (MOTI):	No concerns. MOTI to approve any subdivision or road dedication plan. No storm drainage shall be directed into MOTI systems. This includes collection/run-off of storm drainage from the internal road system. All storm water to be directed to a municipally maintained storm system.
Surrey Fire Department:	No concerns.

B.C. Hydro: The applicant is working with B.C. Hydro to address electric field impacts and ensure sufficient building setbacks are achieved from the B.C. Hydro corridor. Final approval from B.C. Hydro is required before Final Approval.

SITE CHARACTERISTICS

Existing Land Use: Vacant parcel.

Adjacent Area:

Direction	Existing Use	OCP/NCP Designation	Existing Zone
North:	Single family dwellings on acreage parcels	Mixed Employment/Business Park and Creek Preservation Areas	RA
East:	Riparian preservation and City-owned parkland	Urban/Business Park, Creek and Preservation Areas and Multiple Residential (15 – 25 u.p.a.)	RM-30
South:	Single family dwellings on acreage parcels	Mixed Employment and Urban/Business Park and Creek Preservation Areas	RA and IB
West (Across Croydon Drive):	Intersection of Highway No. 99 and 152 Street, beyond which is SouthPoint Exchange Mall	Commercial and Urban/Commercial and Single Family Residential (6 u.p.a.)	RF and CD (By-law Nos. 14763 and 15113)

JUSTIFICATION FOR PLAN AMENDMENT

- The subject property at 3032 Croydon Drive is designated "Mixed Employment" in the Official Community Plan (OCP). An OCP Amendment is required to achieve the proposed land-use in future Phase II and to facilitate consolidation of the subject property with the westerly portion of 3035 – 156 Street, currently designated "Urban" in the OCP.
- The proposed OCP Amendment to re-designate the westerly portion of 3035 – 156 Street from Urban to Mixed Employment (in Figure 3 of the OCP) and to add the westerly portion of 3035 – 156 Street to the Mixed Employment designation (in Figure 42 of the OCP) is consistent with the City's goal of promoting employment activities and fostering business park development in the Rosemary Heights Business Park NCP.
- The adjacent northerly property at 3050 - Croydon Drive is designated "Mixed Employment" in the OCP. The southerly property at 3010 - Croydon Drive will require a similar OCP Amendment on the easterly portion of the site from Urban to Mixed Employment in order to accommodate future development.

DEVELOPMENT CONSIDERATIONS

Background

- The subject property at 3032 Croydon Drive is designated "Mixed Employment" in the Official Community Plan (OCP), "Business Park" and "Creek Preservation Areas" within the Rosemary Heights Business Park Neighbourhood Concept Plan (NCP) and zoned "One-Acre Residential Zone (RA)".
- The applicant proposes to consolidate the property at 3032 Croydon Drive with the westerly portion of 3035 – 156 Street which is designated "Urban" in the OCP as well as "Business Park" and "Creek Preservation Areas" in the Rosemary Heights Business Park NCP.
- The westerly portion of 3035 – 156 Street is zoned "Business Park Zone (IB)". The property is being held "in trust" by the City of Surrey until a purchase agreement is reached between the applicant and Woodbridge Homes (156th) Ltd. The property was originally created as part of the adjacent townhouse development at 3039 – 156 Street under Development Application No. 7911-0243-00. At the time, the westerly portion of 3035 – 156 Street was rezoned to IB with the expectation it would be consolidated with the adjacent industrial properties as part of a larger land assembly and subsequently re-developed for business park uses. The consolidation must be completed by September, 2017 or the City will retain ownership of the IB Zoned portion of 3035 – 156 Street. The applicant is working with Woodbridge Homes (156th) Ltd. to complete the purchase agreement before the September, 2017 deadline.
- The subject property is impacted by a B.C. Hydro right-of-way running through the centre of the site and a tributary to Upper Titman Creek in the northeastern portion of the site, both of which significantly limit development potential. The right-of-way and riparian area affects approximately 7,297 square metres (78,544 sq. ft.) or 68% of the total site area.

Current Proposal

- The applicant proposes an OCP Amendment to re-designate the westerly portion of 3035 - 156 Street from "Urban" to "Mixed Employment" in order to achieve the proposed land-use and to facilitate consolidation with the subject property at 3032 - Croydon Drive which is designated "Mixed Employment" in the OCP.
- The applicant proposes to rezone the property from "One-Acre Residential Zone (RA)" and "Business Park Zone (IB)" to "Comprehensive Development Zone (CD)" (based on the "Business Park (3) Zone") and a Development Permit in order to construct a two-storey multi-tenant business park building along Croydon Drive (Building 1).
- In a future phase of development, the applicant proposes to construct a three-storey multi-tenant business park building on the eastern boundary of the subject property (Building 2). A General Development Permit (DP) is required for the future business park building to set out the general guidelines that will help to ensure a high-quality development is achieved including proposed site access, parking requirements, building form and floor area. A separate detailed DP application is required for future phases of development on the subject property.

- The applicant is proposing a Development Variance Permit (DVP) to vary Part 7A of the Zoning By-law to reduce the minimum setback requirement, measured from top-of-bank, for a Class B watercourse from 15 metres (49 ft.) to 10 metres (33 ft.) to accommodate the proposed development.

Proposed CD By-law

- The proposed CD By-law (Appendix VII) is based on the "Business Park (3) Zone (IB-3)" with modifications to the permitted density, lot coverage, setbacks, building height, landscaping and subdivision requirements. The proposed changes are noted in the table below:

By-law Comparison	IB-3 Zone	Proposed CD Zone
Density	Floor area ratio of 1.00 if amenities are provided in accordance with Schedule G of Surrey Zoning By-law, 1993, No. 12000.	Maximum floor area ratio of 1.09
Lot Coverage	Maximum lot coverage of 60%	Maximum lot coverage of 46%
Setbacks	<u>Principal Building</u> Front = 7.5 m. (25 ft.) Rear = 7.5 m. (25 ft.) Side = 7.5 m. (25 ft.)*	<u>Principal Building</u> Front (West) = 3 m. (10 ft.) Rear (East) = 2.6 m. (9 ft.) Side (North) = 7.5 m. (25 ft.)** Side (South) = 9.5 m. (31 ft.)***
Height	<u>Principal Building</u> 14 m. (46 ft.)	<u>Principal Building</u> 14.6 m. (48 ft.)
Landscaping	Along the developed sides of the lot which abut a highway, a continuous landscaping strip of not less than 3 metres (10 ft.) in width shall be provided from back of curb or projected future curb location.	Along the developed sides of the lot which abut a highway, a continuous landscaping strip of not less than 1.5 metres (5 ft.) in width shall be provided from back of curb or projected future curb location, except at driveways and adjacent to buildings.
Subdivision	Minimum lot width of 30 metres (100 ft.) Minimum lot depth of 30 metres (100 ft.) Minimum lot size of 2,000 sq. m. (0.5 acre)	Minimum lot width of 50 metres (164 ft.) Minimum lot depth of 150 metres (492 ft.) Minimum lot size of 1.85 acres (0.75 hectare)

* One side yard setback may be reduced to 3.6 metres (12 ft.) if adjacent to commercial or industrial land.

** The side (north) yard setback may be reduced to 2.9 metres (10 ft.) at the northwest corner of the subject site.

*** The side (south) yard setback may be reduced to 2.9 metres (10 ft.) at the southwest corner of the subject site.

- The floor area ratio (FAR) of 1.09 is higher than allowed under the IB-3 Zone given that the subject property is significantly encumbered by a B.C. Hydro right-of-way. In addition, the applicant proposes to convey the riparian area to the City for conservation purposes. However, the B.C. Hydro corridor and riparian area are considered undevelopable for the purposes of calculating FAR. If they were included in the calculation, the FAR would be 0.39 over the entire site for the proposed development and, therefore, would be lower than the maximum 1.0 FAR permitted under the IB-3 Zone.
- The minimum setback requirements in the CD By-law reflect site constraints due to the B.C. Hydro right-of-way and riparian area dedication which reduces the overall developable area. The setbacks will provide for functional building envelopes and take into account the setback requirements for future "Building 2" which is proposed as part of a later phase of development. In addition, the setbacks are consistent with the conceptual design for land affected by the B.C. Hydro right-of-way (Appendix VIII) and Design Guidelines for the Rosemary Heights Business Park NCP.
- The proposed density, lot coverage, building height and setback requirements specified in the CD By-law are designed to take into account the multi-tenant building anticipated in Phase II and, therefore, avoid the need to further amend the CD Zone to accommodate future phases of development on-site.
- The landscaping requirements identified in the CD By-law are considered sufficient to provide a suitable visual buffer and is appropriate given a 3 metre (10 ft.) minimum setback was established for the proposed multi-tenant building on Croydon Drive.
- The minimum subdivision requirements prescribed in the CD By-law reflect the current proposal and ensure larger lot consolidations are achieved, in keeping with the Rosemary Heights Business Park NCP.
- All other aspects of the proposed CD By-law comply with the provisions of the IB-3 Zone.

Sensitive Ecosystem Development Permit (Streamside Protection)

- The subject property is located within a Sensitive Ecosystem Development Permit Area, along the northern boundary, for Upper Titman Creek. In accordance with Part 7A of the Zoning By-law, the minimum setback requirement, measured from top-of-bank, for a Class B watercourse is 15 metres (49 ft.). The applicant is requesting a variance to reduce the minimum setback from top-of-bank to 10 metres (33 ft.) in order to accommodate the proposed development.
- The riparian area located directly east of the subject property at 3035 – 156 Street was conveyed to the City for the purposes of riparian protection in 2012 under Development Application No. 7911-0243-00. The riparian protection area was established as part of the Environmental Review Committee (ERC) process which included a representative from the Department of Fisheries and Oceans (DFO).
- The current development application on the subject property was in process at the time the Streamside Protection regulations in Part 7A of the Zoning By-law were adopted by Council on September 12, 2016 (Corporate Report No. R188).

- The applicant submitted a Detailed Riparian Areas Regulations (RAR) Report (dated March 22, 2017) and Peer Review (dated April 18, 2017) which confirm a 10 metre (33 ft.) setback from top-of-bank is RAR compliant and meets the objectives outlined in the OCP for protecting sensitive ecosystems.
- The applicant will convey the Streamside Protection Area, measured to 10 metres (33 ft.) from top-of-bank, to the City for conservation purposes and enter into a P-15 Agreement for the future monitoring and maintenance of replanting within the riparian area.
- In addition, the applicant will register a combined Restrictive Covenant/Statutory Right-of-way over the 5 metre (16 ft.) drainage access corridor along the northern boundary which is provided over and above the Streamside Protection Area.

Sensitive Ecosystem Development Permit (Green Infrastructure)

- The property is located within a Development Permit Area (DPA) for Sensitive Ecosystems (Green Infrastructure) under the Official Community Plan (OCP) given its proximity to a Regional BCS Corridor.
- The City of Surrey Biodiversity Conservation Strategy (BCS) Green Infrastructure Network (GIN) map, adopted by Council on July 21, 2014 (Corporate Report No. R141; 2014), identifies a Regional BCS Corridor (ID #21 and #23) within 50 metres (164 ft.) of the subject property with a low (ID #23) to moderate (ID #21) ecological value.
- A Qualified Environmental Professional (QEP) prepared an Impact Mitigation Plan (IMP) dated March 24, 2017 and revised on June 2, 2017. The IMP confirms that the proposed development will not negatively impact the Regional BCS Corridor along Corydon Drive (ID #23) or the east lot line (ID #21). The IMP notes that the proposed development will provide for additional on-site landscaping opportunities along Corydon Drive which will improve the natural habitat and encourage wildlife movement, particularly songbirds and small mammals. In addition, the BCS corridor located along the eastern boundary of the subject property (ID #21) will not be affected by the development and appears well protected within the existing greenbelt and City-owned parkland.
- As a condition of Development Permit issuance, the applicant will be required to submit a landscape planting plan with appropriate plantings to enhance the portion of the site within the Sensitive Ecosystem DPA.

DESIGN PROPOSAL AND REVIEW

Proposed Building on Corydon Drive (Building 1)

- The applicant is proposing to construct a two-storey multi-tenant business park building on Corydon Drive with approximately 1,174 square metres (12,638 sq. ft.) of office space located within four units.

- The building materials include a hardie-panel reveal system with coloured accents, storefront vinyl windows and entrance doorways, hardie fascia boards, pre-finished metal flashing, glass canopies, metal accent roofs along the eastern building façade as well as second-storey outdoor patios with aluminum and glass railings. The design includes an attractive westerly façade with significant glazing elements that wrap around the southwest corner of the proposed building.
- The proposed building is considered attractive, well-designed and provides an appealing addition to the Rosemary Heights Business Park NCP.

Driveway Access, On-site Parking and Pedestrian Circulation

- The proposed development is seeking to access Croydon Drive through a reciprocal access easement between 3010 - Croydon Drive and the subject property along the southern property line (Appendix II). The intent of this shared access is to maximize the development area of the two sites due to utilities encumbrances on the two properties, along with the diagonal lot lines relative to Croydon Drive.
- The applicant is required to provide a second access point on the northern boundary of 3032 - Croydon Drive to protect for future access to the northern property at 3050 - Croydon Drive. The additional driveway access is required to protect the future development potential of 3050 Croydon Drive as well as to avoid a three-party easement agreement between 3010, 3032 and 3050 - Croydon Drive. Should the property at 3010 - Croydon Drive and 3032 - Croydon Drive be consolidated in future, consideration may be given to eliminating the requirement for a second access point along the northern boundary of 3032 - Croydon Drive.
- The applicant is required to register a reciprocal access easement between 3032 - Croydon Drive and 3010 - Croydon Drive. If the properties are consolidated in future, a new two-party reciprocal access easement could be registered between the consolidated site and 3050 - Croydon Drive. In order to facilitate this alternate reciprocal access arrangement, staff will review the current lot grading plan for Development Application No. 7915-0185-00 to ensure access to 3050 Croydon Drive can be secured through the subject property in future.
- Under the Zoning By-law, a total of twenty-nine parking spaces are required on-site for the proposed office building on Croydon Drive. The applicant proposes to provide seventy-two parking spaces as part of Phase I. An additional fifty-one parking spaces will be provided on-site as part of a future phase of development to ensure there is sufficient on-site parking to accommodate all land-uses.
- Pedestrian connectivity is achieved with the provision of an internal sidewalk that extends directly from the western building façade to the multi-use pathway (Pioneer Greenway) on Croydon Drive.

Signage

- The applicant is proposing one fascia sign along the western building façade for each unit. The fascia signs will consist of individual channel letters with background illumination on a hidden raceway. The fascia signage will not extend more than 0.5 metre (1.6 ft.) from the building façade, in keeping with the Sign By-law.

- The fascia signage will be located directly above the windows or doorway of each unit. No fascia signage is permitted on architectural elements or design features on the exterior of the proposed building.
- The applicant is proposing one upper-storey fascia sign along the western building façade that provides advertising exposure for a major second-storey tenant, per the Sign By-law.
- The upper-storey fascia sign is comprised of individual channel letters with background illumination on a hidden raceway. The fascia signage will not extend more than 0.5 metre (1.6 ft.) from the building façade, in keeping with the Sign By-law.
- No free-standing sign is proposed on-site.

Proposed Landscaping

- The applicant proposes a 1.5 metre (5 ft.) wide landscape buffer along Croydon Drive to separate the boulevard and western façade of the proposed building which includes low-profile planting in the form of small shrubs and additional groundcover.
- A variety of medium-sized trees are proposed along the northern and southern building elevations as well as interspersed throughout the on-site parking areas. The species will consist of Japanese Maple, Bowhall Red Maple, Compact Amur Maple, Shrubby Althea, Purpleleaf Sand Cherry, Ace of Hearts Redbud, Serbian Spruce, Japanese Snowbell and Emerald Green Cedar.
- Decorative paving materials are proposed at the driveway entrance from Croydon Drive.

General Development Permit for Form and Character (Building 2)

- The proposed General Development Permit (DP) was drafted based on the Official Community Plan (OCP) Guidelines and the design guidelines for the Rosemary Heights Business Park NCP. The General DP will be used to guide future phases of development on the subject property. A separate detailed DP application is required for Building 2 when the rear portion of the subject property redevelops in future.
- The General DP will provide direction and establish guidelines for evaluating any detailed DP application submitted as part of a future phase of development. The General DP includes the following information:
 - Overall site design (e.g. layout, access and circulation);
 - Building information (e.g. floor plans, total floor area, building height, setbacks); and
 - Preliminary parking calculations.
- The applicant has indicated that proposed Building 2 will include the following:
 - The proposed building is three-stories with a total height of 14.6 metres (48 ft.);
 - The ground-floor is estimated to be 987.4 square metres (10,600 sq. ft.) in total area;

- The building is expected to have a total floor area of 2,954 square metres (31,800 sq. ft.);
 - The estimate lot coverage is 25.9%;
 - The estimated floor area ratio (FAR) for Building 2 is 0.78;
 - The applicant anticipates that display, office and warehouse uses will occupy the ground-floor with office uses on the second- and third-floors of the proposed building;
 - The proposed building will require a minimum of 67 parking spaces. A total of 51 stalls are provided in Phase II. A further 72 parking spaces are provided in Phase I for a total of 123 parking spaces on-site in future. A total of 96 parking spaces are required on-site to accommodate all proposed land-uses in Phase I and Phase II;
 - The proposed building will utilize the reciprocal access easement required between 3010 - Croydon Drive and 3032 - Croydon Drive as part of Phase I of the development;
 - The building materials will include tilt-up concrete panels with generous glazing elements and strategically placed masonry accent materials at the main entrance; and
 - The proposed building will reflect the general form, design and character of the proposed building on Croydon Drive constructed as part of Phase I (Building 1).
- Overall, the proposed building will be consistent with development in the Rosemary Heights Business Park area and will maintain a high-standard in terms of the form, design and character of future business park buildings within the surrounding neighbourhood.

PRE-NOTIFICATION

Pre-notification letters were mailed to 240 property owners within 100 metres (300 ft.) of the subject property on May 2, 2017. Staff received the following response from a nearby property owner. Staff comments are provided in italics:

- The resident indicated the subject property should remain single family residential and expressed concerns about potential impacts to adjacent parkland as well as the need for more open space.

(The proposal is consistent with the "Mixed Employment" designation in the OCP and "Business Park" designation in the Rosemary Heights Business Park NCP. In addition, a similar business park development was recently constructed to the north at 3088 - Croydon Drive / 15336 - 31 Avenue.

The applicant is proposing to consolidate the subject property at 3032 - Croydon Drive with the westerly portion of 3035 - 156 Street which, as noted above, was originally intended to become part of a larger business park development. No additional parkland or open space is affected by the current proposal. Furthermore, the applicant proposes to dedicate the riparian area to the City for conservation purposes which further expands the adjacent City-owned parkland and greenbelt to provide more open space.)

TREES

- Nick McMahon, ISA Certified Arborist of Arbortech Consulting prepared an Arborist Assessment for the subject property. The table below provides a summary of the tree retention and removal by tree species:

Table 1: Summary of Tree Preservation by Tree Species:

Tree Species	Existing	Remove	Retain
Alder and Cottonwood Trees			
Red Alder	25	25	0
Black Cottonwood	2	2	0
Deciduous Trees (excluding Alder and Cottonwood Trees)			
Bigleaf Maple	7	7	0
Black Locust	2	2	0
Coniferous Trees			
Grand Fir	2	2	0
Douglas Fir	5	5	0
Western Red Cedar	3	3	0
Total (excluding Alder and Cottonwood Trees)	19	19	0
Additional Trees in the proposed Riparian Area	10	0	10
Total Replacement Trees Proposed (excluding Boulevard Street Trees)		54	
Total Retained and Replacement Trees		54	
Contribution to the Green City Fund		\$4,400	

- The Arborist Assessment states that there are a total of 19 protected trees on the site, excluding Alder and Cottonwood trees. Twenty-seven existing trees, approximately fifty-nine percent of the total trees on the site, are Alder and Cottonwood trees. It was determined that no trees could be retained in Phase I as part of the development proposal. The proposed tree retention was assessed taking into consideration the location of services, building footprints, road dedication and proposed lot grading.
- The applicant has indicated that no trees will be cleared in advance of Phase II. All trees at the rear of the site will be re-assessed for retention/removal as part of a detailed DP application for future phases of development (i.e. Building 2).

- Table 1 includes an additional 10 protected trees that are located within the riparian area. The trees within the riparian area will be retained, except where removal is required due to hazardous conditions. This will be determined at a later time, in consultation with the Parks, Recreation and Culture Department.
- A detailed planting plan prepared by a Registered Professional Biologist (R.P. Bio.) and an associated P-15 agreement are required for the monitoring and maintenance of the proposed trees to be planted in the conveyed riparian area.
- For those trees that cannot be retained, the applicant will be required to plant trees on a 1 to 1 replacement ratio for Alder and Cottonwood trees, and a 2 to 1 replacement ratio for all other trees. This will require a total of 65 replacement trees on the site. Since only 54 replacement trees can be accommodated on the site, the deficit of 11 replacement trees will require a cash-in-lieu payment of \$4,400, representing \$400 per tree, to the Green City Fund, in accordance with the City's Tree Protection By-law.
- The new trees on the site will consist of a variety of trees including Japanese Maple, Bowhall Red Maple, Compact Amur Maple, Shrubby Althea, Purpleleaf Sand Cherry, Ace of Hearts Redbud, Serbian Spruce, Japanese Snowbell and Emerald Green Cedar.
- In summary, a total of 54 replacement trees are proposed on the site with a contribution of \$4,400 to the Green City Fund.

PUBLIC CONSULTATION PROCESS FOR OCP AMENDMENT

Pursuant to Section 879 of the Local Government Act, it was determined that it was not necessary to consult with any persons, organizations or authorities with respect to the proposed OCP amendment, other than those contacted as part of the pre-notification process.

SUSTAINABLE DEVELOPMENT CHECKLIST

The applicant prepared and submitted a sustainable development checklist for the subject site on March 30, 2017. The table below summarizes the applicable development features of the proposal based on the seven (7) criteria listed in the Surrey Sustainable Development Checklist.

Sustainability Criteria	Sustainable Development Features Summary
1. Site Context & Location (A1-A2)	<ul style="list-style-type: none"> • The subject property is located within the Rosemary Heights Business Park NCP.
2. Density & Diversity (B1-B7)	<ul style="list-style-type: none"> • N/A

Sustainability Criteria	Sustainable Development Features Summary
3. Ecology & Stewardship (C1-C4)	<ul style="list-style-type: none"> • The development incorporates Low Impact Development Standards (LIDS) in the form of absorbent soils, roof downspout disconnection, on-lot infiltration trenches or sub-surface chambers, sediment control devices, cisterns/rain barrels, vegetated swales/rain gardens/bio-swales and natural landscaping. • The applicant will provide on-site tree replacement. • The applicant will convey the riparian area, measured to 10 metres (33 ft.) from top-of-bank, to the City of Surrey for conservation purposes. • The proposed development will have access to organic waste pick-up.
4. Sustainable Transport & Mobility (D1-D2)	<ul style="list-style-type: none"> • The proposed development is connected to off-side pedestrian and multi-use pathways (Pioneer Greenway) located on Croydon Drive. • The proposal includes covered outdoor waiting areas, pedestrian-specific lighting, bike racks and/or lockers and direct pedestrian linkages to transit stops.
5. Accessibility & Safety (E1-E3)	<ul style="list-style-type: none"> • The proposal includes clear site lines, a well-lit building exterior and low-lying planting to provide for visual surveillance, in accordance with Crime Prevention Through Environmental Design (CPTED) principles.
6. Green Certification (F1)	<ul style="list-style-type: none"> • N/A
7. Education & Awareness (G1-G4)	<ul style="list-style-type: none"> • The development application review process includes pre-notification letters, a development proposal sign and a Public Hearing which offers concerned residents an opportunity to review/discuss the proposal.

ADVISORY DESIGN PANEL

In response to financial requirements and timeline constraints, the proposal was not forwarded to the Advisory Design Panel (ADP) for comment.

The proposed development has been reviewed internally by City staff and deemed to be generally acceptable in terms of form, design and character. The applicant has agreed to resolve a number of urban design issues before final adoption, primarily related to the following:

- Co-ordination of the architectural drawings to reflect the current design;
- Provide additional information on proposed exterior materials and/or finishes;
- Introduction of additional design elements (e.g. cornice features, masonry finishes, etc.);
- Provide weather protection canopies over building entrances with canopy details to ensure the canopies are architecturally integrated into the overall building design;
- Co-ordination of the landscaping proposed beneath the canopies to minimize overhangs;
- Replacement of the retaining wall that is proposed along the northern elevation with stairs that meet natural grade and relocate the retaining wall in the parking area to provide a minimum 1.5 metre setback with landscape screening and guard rails; and

- Provision of a different specialty paving material at the driveway entrance.

BY-LAW VARIANCE AND JUSTIFICATION

(a) Requested Variance:

- To reduce the minimum setback requirement from top-of-bank for a Class B watercourse from 15 metres (49 ft.) to 10 metres (33 ft.) at the closest point to accommodate the proposed development.

Applicant's Reasons:

- The applicant is requesting a setback relaxation from 15 metres (49 ft.) to 10 metres (33 ft.) from the Class B watercourse along the northern boundary of the subject property in order to construct a multi-tenant business park building in Phase II with a functional building envelope.

Staff Comments:

- According to the streamside setbacks established under Part 7A of the Zoning By-law, the minimum setback requirement from top-of-bank for a Class B watercourse is 15 metres (49 ft.).
- The development application on the subject property was in process at the time the Streamside Protection regulations were adopted by Council on September 12, 2016 (Corporate Report No. R188).
- The applicant submitted a Detailed Riparian Areas Regulations (RAR) Report (dated March 22, 2017) and Peer Review (dated April 18, 2017) which confirm a 10 metre (33 ft.) setback from top-of-bank is RAR compliant and meets the objectives outlined in the OCP for protecting sensitive ecosystems.
- The applicant will convey the Streamside Protection Area, measured to 10 metres (33 ft.) from top-of-bank, to the City for conservation purposes as well as enter into a P-15 Agreement for the future monitoring and maintenance of replanting within the riparian area.
- In addition, the applicant will register a combined Restrictive Covenant/Statutory Right-of-way over the 5 metre (16 ft.) drainage access corridor along the northern boundary which is provided over and above the Streamside Protection Area.
- Given that a Qualified Environmental Professional (QEP) has confirmed the proposed 10 metre (33 ft.) setback, measured from top-of-bank, for the Class B watercourse along the northern boundary of the subject property is RAR compliant and various protection measures employed by the applicant (e.g. riparian area dedication, entering into a P-15 agreement, etc.), staff support the proposed variance.

INFORMATION ATTACHED TO THIS REPORT

The following information is attached to this Report:

Appendix I.	Lot Owners, Action Summary, Project Data Sheets and Survey Plan
Appendix II.	Site Plan, Building Elevation Drawings and Landscape Plans
Appendix III.	Engineering Summary
Appendix IV.	Summary of Tree Survey and Tree Preservation
Appendix V.	Development Variance Permit No. 7915-0185-00
Appendix VI.	OCP Re-designation Map
Appendix VII.	Proposed CD By-law
Appendix VIII.	Rosemary Heights Business Park NCP Design Guidelines, Figure #3 – Potential Site Design for Business Park Development Adjacent to Hydro Lines

INFORMATION AVAILABLE ON FILE

- Environmental Report Prepared by Phoenix Environmental Services Dated March 22, 2017 and revised June 2, 2017 as well as Envirowest Consultants Ltd. Dated April 18, 2017.
- Complete Set of Architectural and Landscape Plans prepared by Ionic Architecture Inc. and Maruyama & Associates Landscape Architects, respectively, dated May 23, 2017 and June 2, 2017.

original signed by Ron Hintsche

Jean Lamontagne
General Manager
Planning and Development

MRJ/da

Information for City Clerk

Legal Description and Owners of all lots that form part of the application:

1. (a) Agent: Name: Maggie Koka
 Aplin & Martin Consultants Ltd.
 Address: 13450 – 102 Avenue, Suite #1680
 Surrey, BC V3T 5X3

2. Properties involved in the Application

- (a) Civic Address: 3032 - Croydon Drive
 3035 – 156 Street
- (b) Civic Address: 3032 - Croydon Drive
 Owner: Rosemary Business Park Ltd.
 PID: 011-419-920
 Parcel "A" (M26060E) Lot 3 Section 23 Township 1 New Westminster District Plan 9266
- (c) Civic Address: 3035 – 156 Street
 Owner: City of Surrey
 PID: 028-916-786
 Lot 2 Section 23 Township 1 New Westminster District Plan BCP51422

3. Summary of Actions for City Clerk's Office

- (a) Introduce an OCP Amendment By-law to:
 - amend "Figure 3: General Land Use Designations" by re-designating a portion of the subject property at 3035 – 156 Street from Urban to Mixed Employment; and
 - amend "Figure 42: Major Employment Areas" by adding the Mixed Employment designation to a portion of the subject property at 3035 – 156 Streetand a date be set for Public Hearing.
- (b) Introduce a By-law to rezone the property.
- (c) Application is under the jurisdiction of MOTI.

MOTI File No. 2017-03592
- (d) Proceed with Public Notification for Development Variance Permit No. 7915-0185-00 and bring the Development Variance Permit forward for an indication of support by Council. If supported, the Development Variance Permit will be brought forward for issuance and execution by the Mayor and City Clerk in conjunction with the final adoption of the associated Rezoning By-law.

DEVELOPMENT DATA SHEET

Proposed Zoning: CD (based on IB-3)

Required Development Data	Minimum Required / Maximum Allowed	Proposed
LOT AREA* (in square metres)		
Gross Total	N/A	10,790 sq. m.
Road Widening area	N/A	128.5 sq. m.
Undevelopable area	N/A	6,860 sq. m.
Net Total	N/A	3,802.3 sq. m.
LOT COVERAGE (in % of net lot area)		
Buildings & Structures	N/A	N/A
Paved & Hard Surfaced Areas	N/A	N/A
Total Site Coverage	46%	46%
SETBACKS (in metres)		
Front (West)	7.5 m.	2.9 m.
Rear (East)	7.5 m.	2.6 m.
Side (North)	7.5 m./3.6 m.	7.5 m.
Side (South)	7.5 m./3.6 m.	9.5 m.
BUILDING HEIGHT (in metres/storeys)		
Principal	14 m.	14.6 m.
Accessory	6 m.	6 m.
FLOOR AREA: Residential	N/A	N/A
FLOOR AREA: Commercial	N/A	N/A
FLOOR AREA: Industrial		
Building 1	N/A	1,174 sq. m.
Building 2	N/A	2,954 sq. m.
FLOOR AREA: Institutional	N/A	N/A
TOTAL BUILDING FLOOR AREA	N/A	4,128 sq. m.

** If the development site consists of more than one lot, lot dimensions pertain to the entire site.*

Development Data Sheet cont'd

Required Development Data	Minimum Required / Maximum Allowed	Proposed
DENSITY		
# of units/ha /# units/acre (gross)	N/A	N/A
# of units/ha /# units/acre (net)	N/A	N/A
FAR (gross)	N/A	N/A
FAR (net)	1.09	1.09
AMENITY SPACE (area in square metres)	N/A	N/A
Indoor		
Outdoor		
PARKING (number of stalls)		
Commercial	N/A	N/A
Industrial		
Building 1	29 stalls	72 stalls
Building 2	67 stalls	51 stalls
Residential	N/A	N/A
Institutional	N/A	N/A
Total Number of Parking Spaces	96 stalls	123 stalls
Number of accessible stalls	1 stall	1 stall
Number of small cars	N/A	N/A
Tandem Parking Spaces	N/A	N/A
Size of Tandem Parking Spaces	N/A	N/A

Heritage Site	NO	Tree Survey/Assessment Provided	YES
---------------	----	---------------------------------	-----

**SURVEY PLAN TO ACCOMPANY
CITY OF SURREY
REZONING BYLAW# _____ OF
PARCEL "A" (M2606E) LOT 3 PLAN 9266, AND
PART OF LOT 2 PLAN BCP51422,
BOTH OF SECTION 23 TOWNSHIP 1
NEW WESTMINSTER DISTRICT**

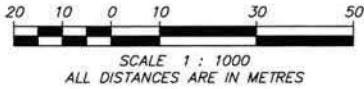

SRW PLAN EPP38083
SRW PLAN BCP36390 &
SRW PLAN BCP36738

STRATA PLAN EPS3737

B.C. HYDRO & POWER
AUTHORITY SRW
CHARGE #E51153

SRW PLAN BCP21206 &
SRW PLAN BCP24415

2
PLAN EPP39658
Sec 23

SRW PLAN BCP36390 &
SRW PLAN BCP36738
3
PLAN EPP39658

PARK
PLAN BCP39265

CROYDON

SRW
PLAN
B363

B.C. HYDRO & POWER
AUTHORITY SRW
CHARGE #333291C

Rem 2
PLAN 9266

SRW PLAN
BCP21206

TP 1

90°01'09"
12.550 93°02'40"



HIGHWAY No. 99
PLAN 25810

PARCEL "A"
(M2606E)
LOT 3
PLAN 9266

B.C. HYDRO & POWER
AUTHORITY SRW
CHARGE #333842C

BLOCK A
1.16 ha.

SRW PLAN BCP21206

PART
2
572.3m2
PLAN

PART 2
BCP51422

BLOCK B

7.238
90°02'00"

81°01'41"

SRW
PLAN
EPP47843

COVENANT PLAN
BCP41792

SRW PLAN
BCP21206

CERTIFIED CORRECT ACCORDING TO SURVEY
DATED THIS 19th DAY OF MAY, 2017.

JRE
JAMES R. ENDERS, BCLS 659

DRIVE

1
PLAN EPP43507

B.C. HYDRO & POWER
AUTHORITY SRW
CHARGE # 333715C

SRW PLAN BCP21206
& SRW PLAN BCP24413

MURRAY & ASSOCIATES
PROFESSIONAL LAND SURVEYORS
201-12448 82nd AVENUE
SURREY, BC V3W 3E9
(604) 597-9189

xx\JOBR\15-1530_Norm_3032 Croydon Dr V2-development permit\A05-23-2017_DP submission stage 1\15-1530 A.100 Site data.dwg, 5/24/2017 11:39:38 AM

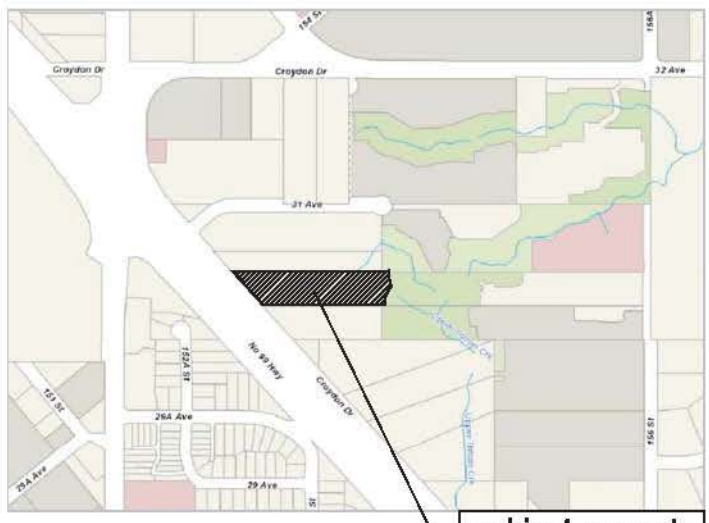
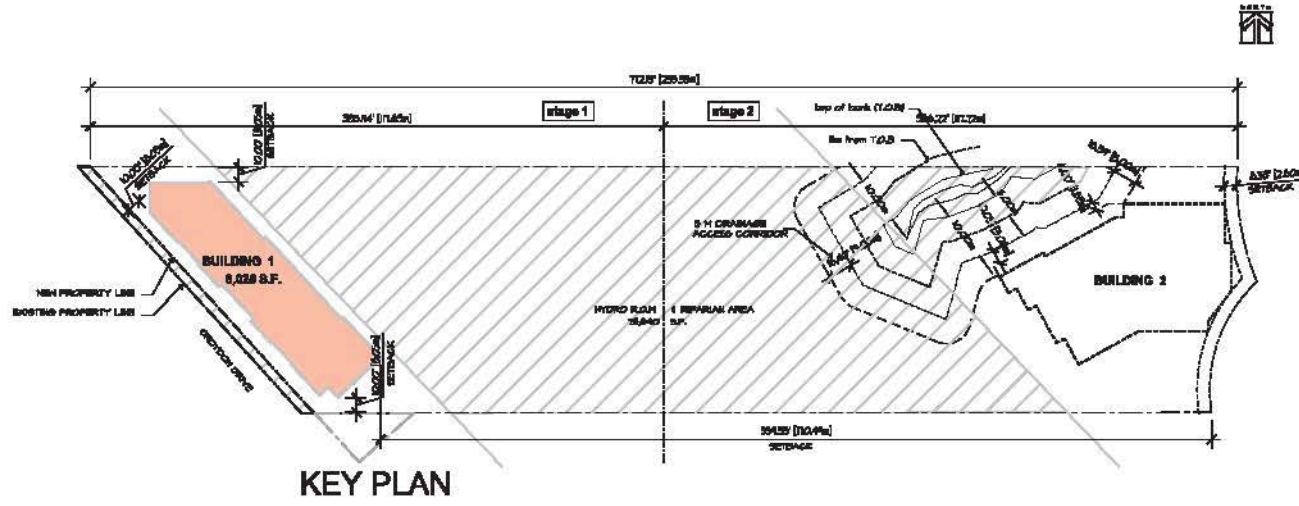

subject property

DRAWING INDEX :

- A001 SITE DATA
- A002 SITE PLAN
- A003 DETAIL SITE PLAN
- A004 SITE SURVEY - BASE PLAN
- A005 Blg. 1 - FLOOR PLANS
- A006 Blg. 1 - ELEVATIONS & SECTIONS
- A007 SITE DETAILS - ROOF PLAN
- A008 SITE DETAILS

LEGAL DESCRIPTION :

Sec. 23 TP. 1 Plan 9288 N.W.D.
 PARCEL A - LOT 3, PART NW 1/4

site data & notes :

ADDRESS : 3032 Croydon Drive, SURREY, B.C.

EXISTING ZONING : RA
 PROPOSED ZONING : CD BASED ON I5-S

site statistics :

GROSS SITE AREA	62,740 SQ.M (2,421 ac)	14,850 S.F.
HYDROLOGIC & TERRAIN AREA	(measured to 5 meters from top-of-bank)	
	5,860 SQ.M (5.1 ha = 13 acres)	75,440 S.F.
TRAIL DEDICATION	3,365 SQ.M (3,008 sq = 0.008 acre)	4,985 S.F.
NET SITE AREA	56,515 SQ.M (50.4 acre)	40,927 S.F.

Blg. 1

DENSITY ALLOWED - CDO (per IS standards) = 0.2 (based on gross site area)

DENSITY PROVIDED - P.A.S. 17,400 S.F. 13,000 S.F. = 0.2 (based on net site area)

BUILDING I ONLY P.A.S. 17,400 S.F. 13,000 S.F. = 0.2 (based on net site area)

PROPOSED FLOOR AREA:

BUILDING I	GROUND FLOOR	4,020 S.F.
	SECOND FLOOR	4,008 S.F.
		TOTAL 8,028 S.F.

COVERAGE PROVIDED:

8,028 S.F. / 40,927 S.F. = 0.20

SETBACK REQUIREMENTS - IS 8

SETBACK	REQUIREMENTS	PROVIDED	VARIED
FRONT [FEET]	1.5m [50.0']	5.0m [16.40']	REQUIRED
SIDE (NORTH)	1.5m [50.0']	5.0m [16.40']	REQUIRED
SIDE (SOUTH)	1.5m [50.0']	5.0m [16.40']	REQUIRED
REAR (DEPT)	1.5m [50.0']	10.0m [32.81']	NOT REQUIRED
BUILDING HEIGHT	4m [13.12']	1.65m [5.41']	NOT REQUIRED

INCLUDE I ONLY

ground floor = 4,020 S.F. OFFICES
 second floor = 4,008 S.F. OFFICES
 total = 8,028 S.F.

PARKING REQ'D:
 0.25 parking spaces per 1775 S.F. for office use

8,028 / 1775 x 0.25 = 2.1 spaces

PARKING PROVIDED: 23 spaces STAGES I ONLY

NOTE

TYPICAL PARKING SPACE SIZES:
 SMALL SPACE 8'0" x 18'0"
 HANDICAP SPACE 12'0" x 20'0"

PROVIDE CURB LET DOWN TO ALL PATH AND WALKWAYS FROM PARKING AREA AT LOCATIONS INDICATED (I.G. GROUP CURB)

PROVIDE BIKE RACKS AT LOCATIONS INDICATED (I.R.)

PROVIDE AT LEAST ONE CONC. CURB AT LANDSCAPING AREA & PARKING ISLANDS AS INDICATED.

PROVIDE 4" CONC. W/ER. STOPS SECURED BY DEFORMED BARS WHERE THERE IS NO CURB.

SEWER/LEES - 4" CONC. ON HILL & COMPACTED GRANULAR FILL, PROVIDE PERFORATED 18" ADJACENT BLDG. AS SCHEDULED, CONTROL JOINTS @ 8' O.C. MAX. (28' STRIPS)

PROVIDE SIGN ABOVE ST. PT. ABOVE THE FIRE DEPARTMENT CONNECTION INDICATING FIRE DEPARTMENT CONNECTION

IONIC ARCHITECTURE INC.
 architect - member a.i.a.a.
 2600 WEST 10TH AVENUE, SUITE 100
 VANCOUVER, BC V6L 2K6

PROJECT NO. 15-1530-0001
 DRAWING NO. 15-1530-0001-002

DATE: 5/24/2017

APPENDIX II



BUILDING I SITE PLAN

Scale 1"=40'

EXISTING PROPERTY LINE
NEW PROPERTY LINE

SEE DETAIL SITE PLAN
A 102

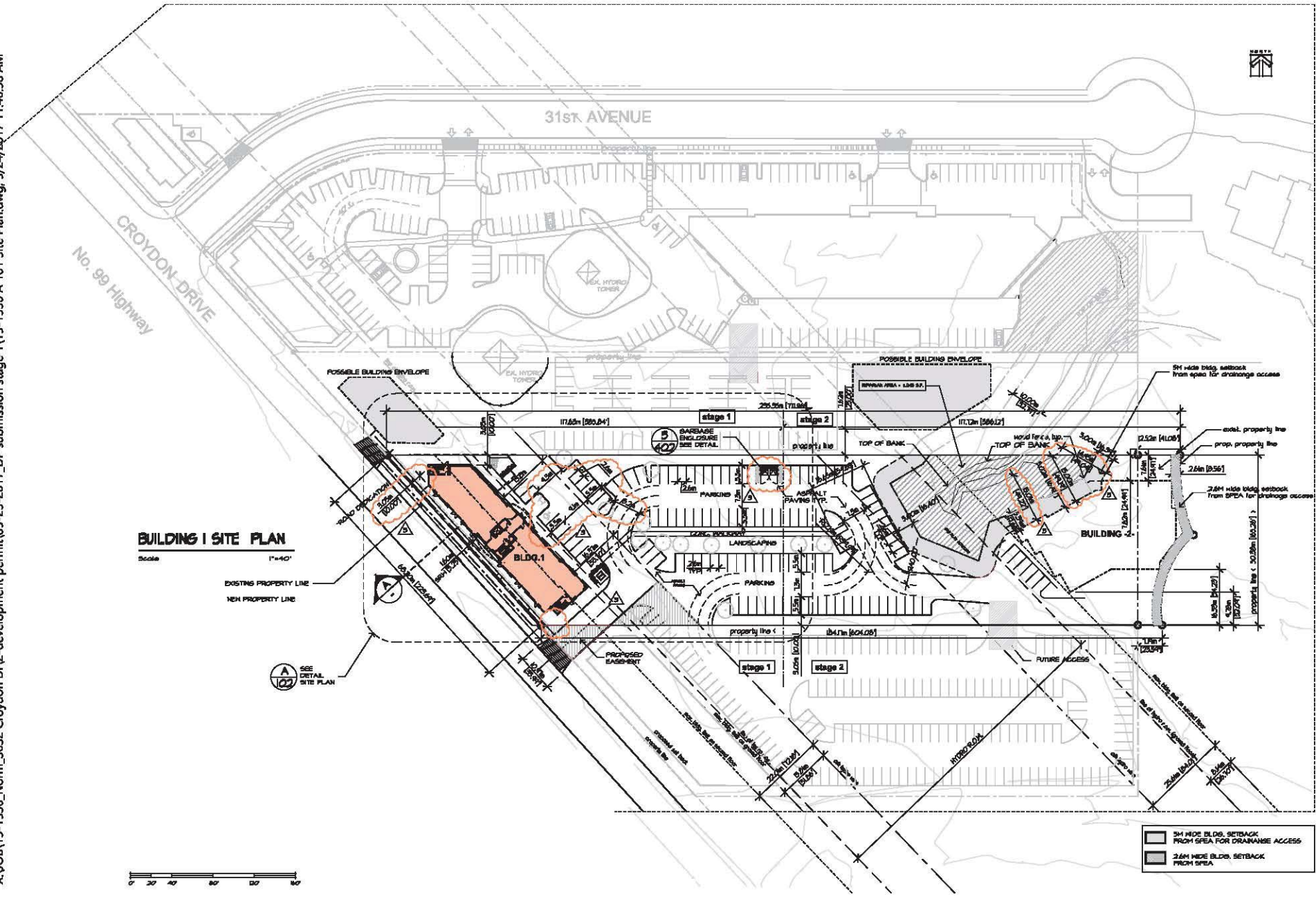

- 3M WIDE BLDG. SETBACK FROM SFEA FOR DRAINAGE ACCESS
- 2.6M WIDE BLDG. SETBACK FROM SFEA

Name: Iomic Architecture Inc. Date: 05-23-17 Number: 15-1530	Project Name: SITE PLAN Project Number: A101	Client: Iomic Architecture Inc. architect-member a.i.b.c. 3032 Croydon Drive Surrey, BC	Revision History: 03 08-23-17 ISSUED FOR IP SUBMISSION 04 04-07-17 ISSUED FOR IP SUBMISSION 05 08-23-18 ISSUED FOR IP SUBMISSION Date: _____ By: _____ Description: _____
--	---	--	---

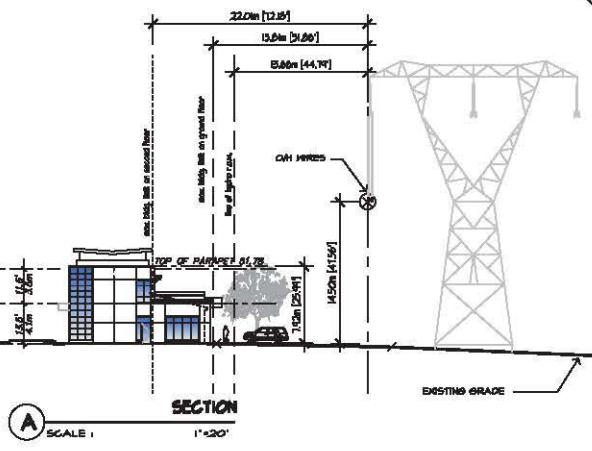
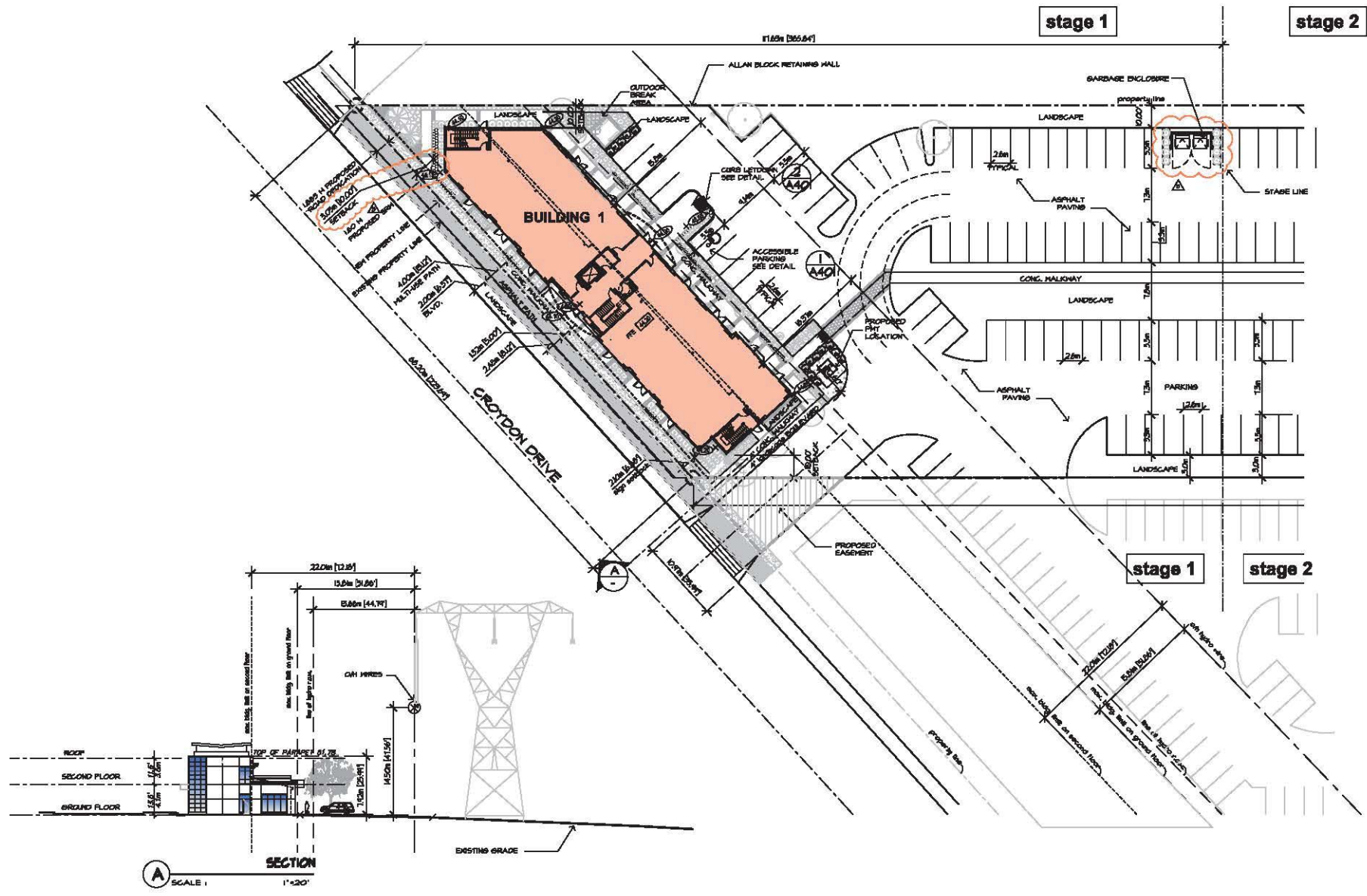

A SCALE: 1" = 20'

stage 1

stage 2

stage 1

stage 2

Project Name	15-1530	Project No.	A102
Client	Proposed Commercial Buildings	Address	3032 Croydon Drive, Surrey, BC
Architect	Ionic Architecture Inc.	Architect Member	a.i.b.c.
Issue	DP	Issue Date	05-23-17
Revision	1	Revision Description	ISSUED FOR SUBMISSION
Revision	2	Revision Description	ISSUED FOR SUBMISSION
Revision	3	Revision Description	ISSUED FOR SUBMISSION
Revision	4	Revision Description	ISSUED FOR SUBMISSION
Revision	5	Revision Description	ISSUED FOR SUBMISSION

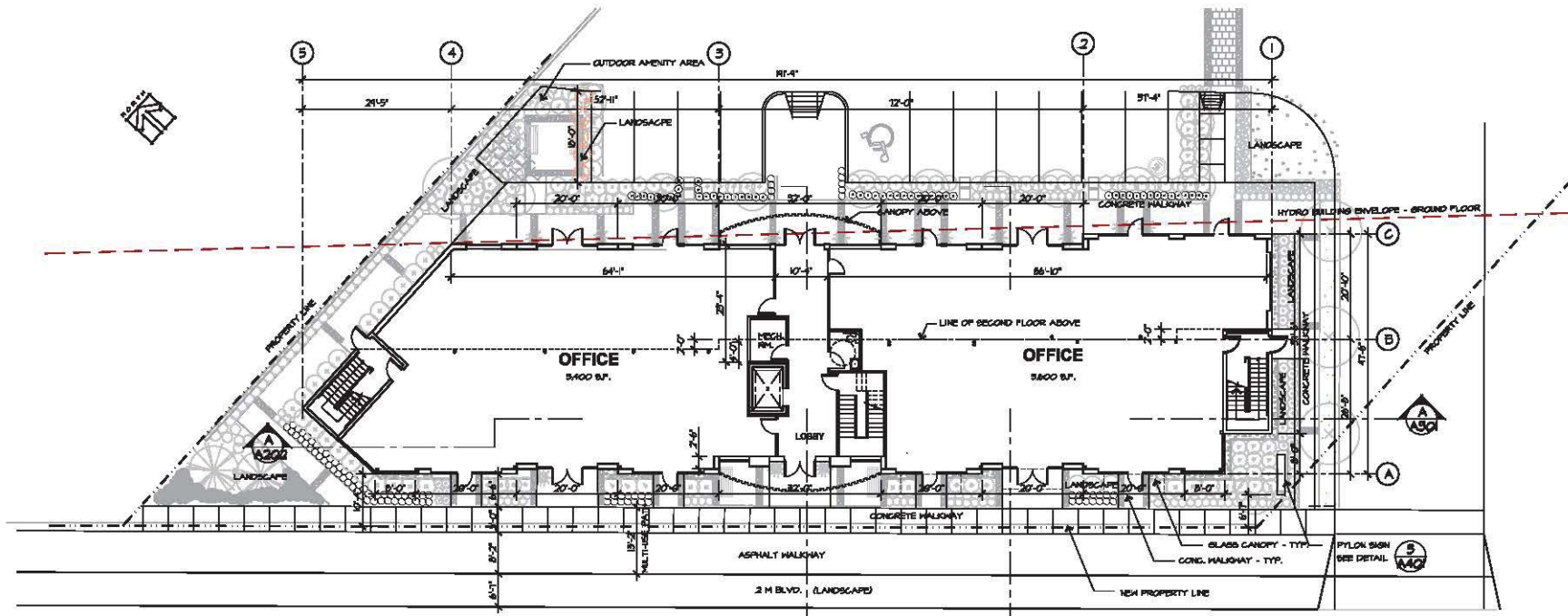

GROUND FLOOR PLAN
Scale 3/32"=1'-0" 5,020 SQ. FT.

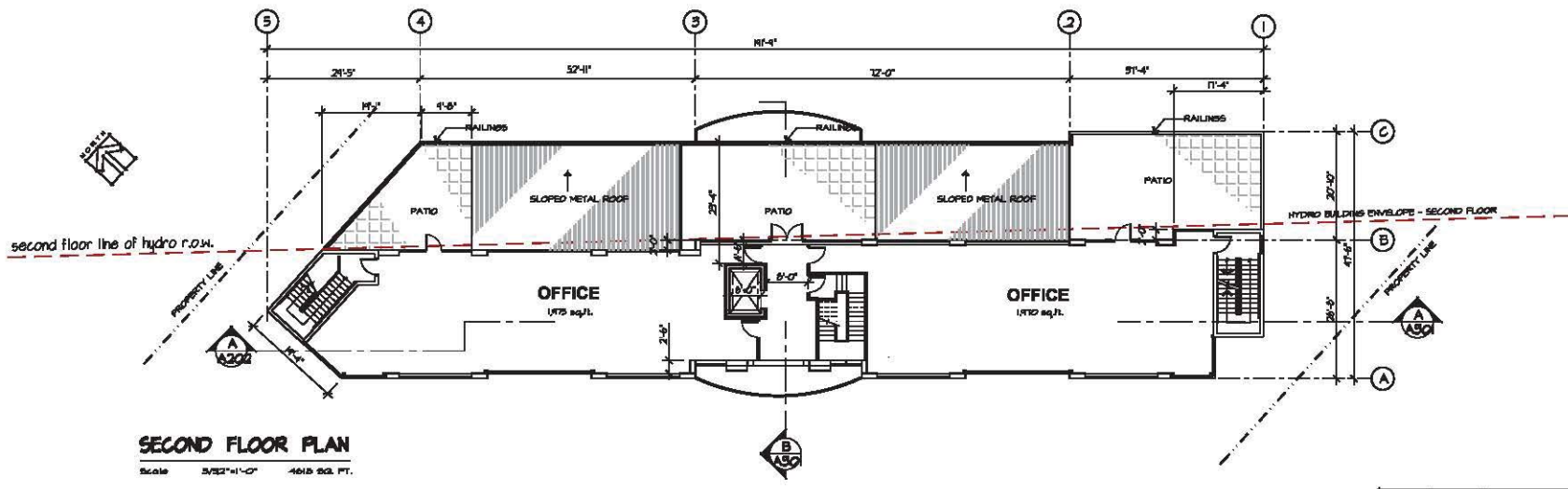

SECOND FLOOR PLAN
Scale 3/32"=1'-0" 4,615 SQ. FT.



Bldg. 1

Revision	As Issued	Sheet	of	Drawing Title BLDG. 1 - FLOOR PLANS
01	SEP. 2016			Project Name PROPOSED COMMERCIAL BUILDINGS
		A201		Project No. 15-1530
				Designer IONIC ARCHITECTURE INC.
				Architect - member a.i.a.a.c. IONIC ARCHITECTURE INC.
				26-6688 2nd Street Surrey B.C. V3W 2A8 Tel: 604-272-2222 Fax: 604-272-2222 www.ionic-architecture.com
				Description FLOOR PLAN
				Date 05-23-16
				Date 05-23-16

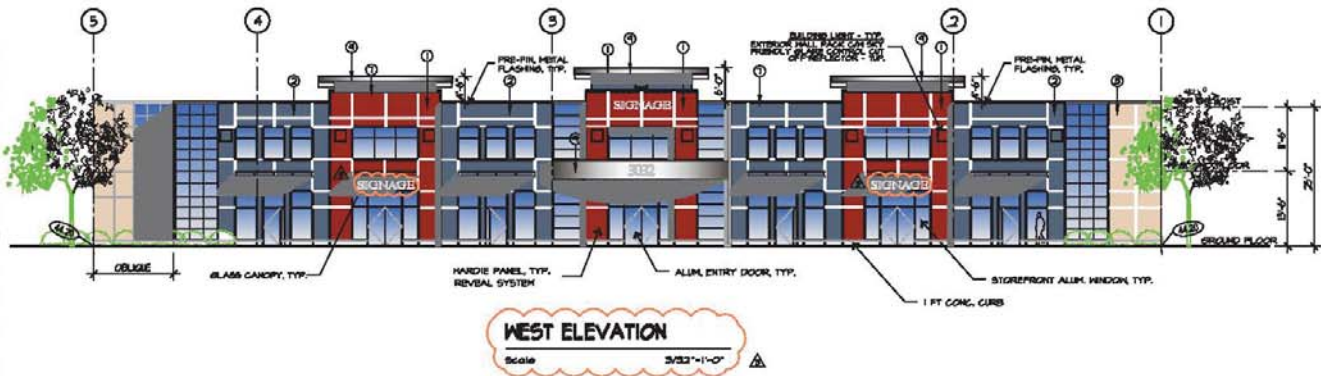

WEST ELEVATION
Scale: 3/32"=1'-0"

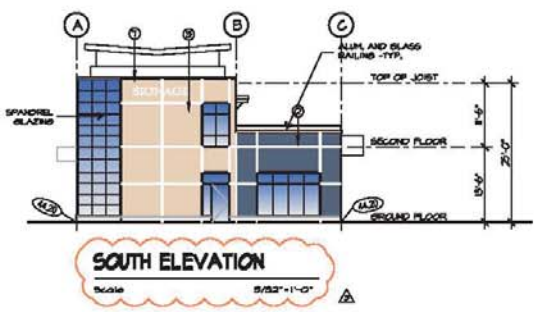

SOUTH ELEVATION
Scale: 3/32"=1'-0"

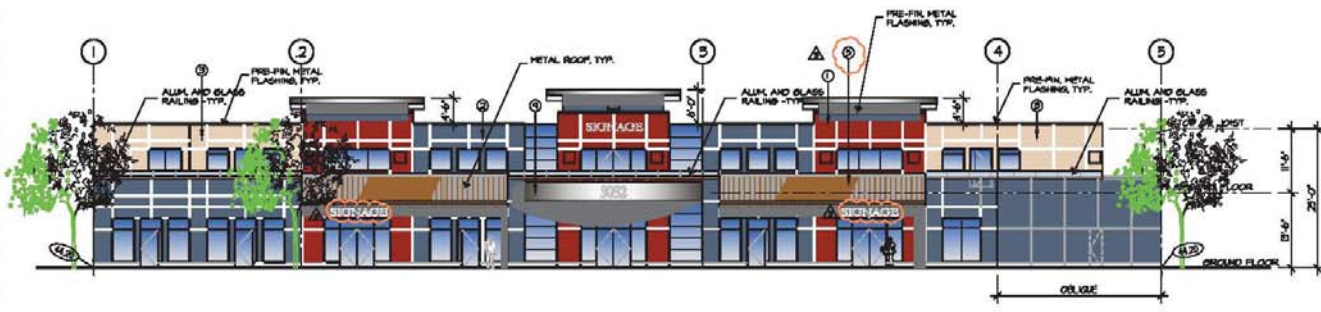

EAST ELEVATION
Scale: 3/32"=1'-0"

EXTERIOR MATERIALS & FINISHES	
MATERIAL / FINISH	COLOR
① PANEL-REVEAL SYSTEM	** TRADITIONAL RED
② PANEL-REVEAL SYSTEM	** EVENING BLUE
③ PANEL-REVEAL SYSTEM	** COBBLE STONE
④ VENT. WINDOWS & DOORS	CLEAR ANODIZED FRAME TINTED BLUE GLASS
⑤ METAL ROOF	LIGHT BROWN
⑥ HARDE FASCIA	** COBBLE STONE
⑦ PREFINISHED METAL FLASHING	CLEAR ANODIZED
⑧ METAL AND GLASS RAILING	CLEAR ANODIZED
⑨ METAL PANEL	CLEAR ANODIZED

* BRICK - MIXED MATERIALS.
** WALL PANEL - JAMES HARDE-HARDE PANEL REVEAL SYSTEM

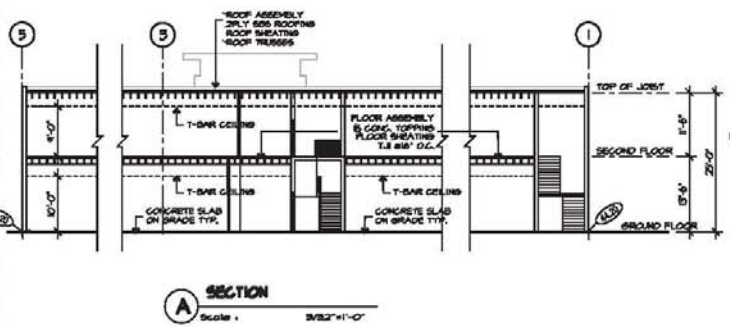

A SECTION
Scale: 3/32"=1'-0"

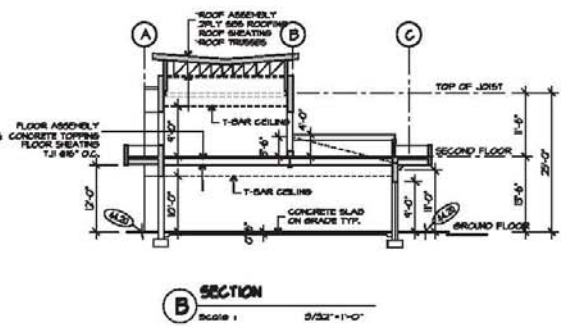

B SECTION
Scale: 3/32"=1'-0"

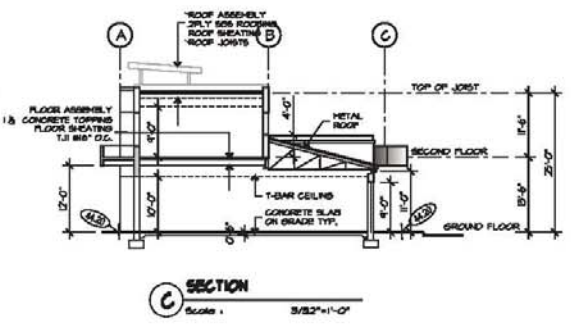

C SECTION
Scale: 3/32"=1'-0"



<p>Ionic Architecture Inc. architect - member a.i.a.a. 3032 Croydon Drive Surrey, BC V3Z 9L8 Tel: 778 442-8888 info@ionic-arch.com</p>	<p>BLDG. 1 - ELEVATIONS & SECTIONS PROPOSED COMMERCIAL BUILDINGS 3032 Croydon Drive Surrey, BC</p>
<p>Sheet: A301</p>	<p>Scale: 3/32"=1'-0"</p>
<p>Date: 05/24/2017</p>	<p>Project No: 15-1530</p>
<p>Drawn: 01</p>	<p>Revision: 01</p>

Bldg. 1

X:\JOB\15-1530_Norm_3032 Croydon Dr\2-development permit\06-02-2017_concept STAGE 2\15-1530_stage 2_site plan.dwg, 6/4/2017 3:32:20 PM

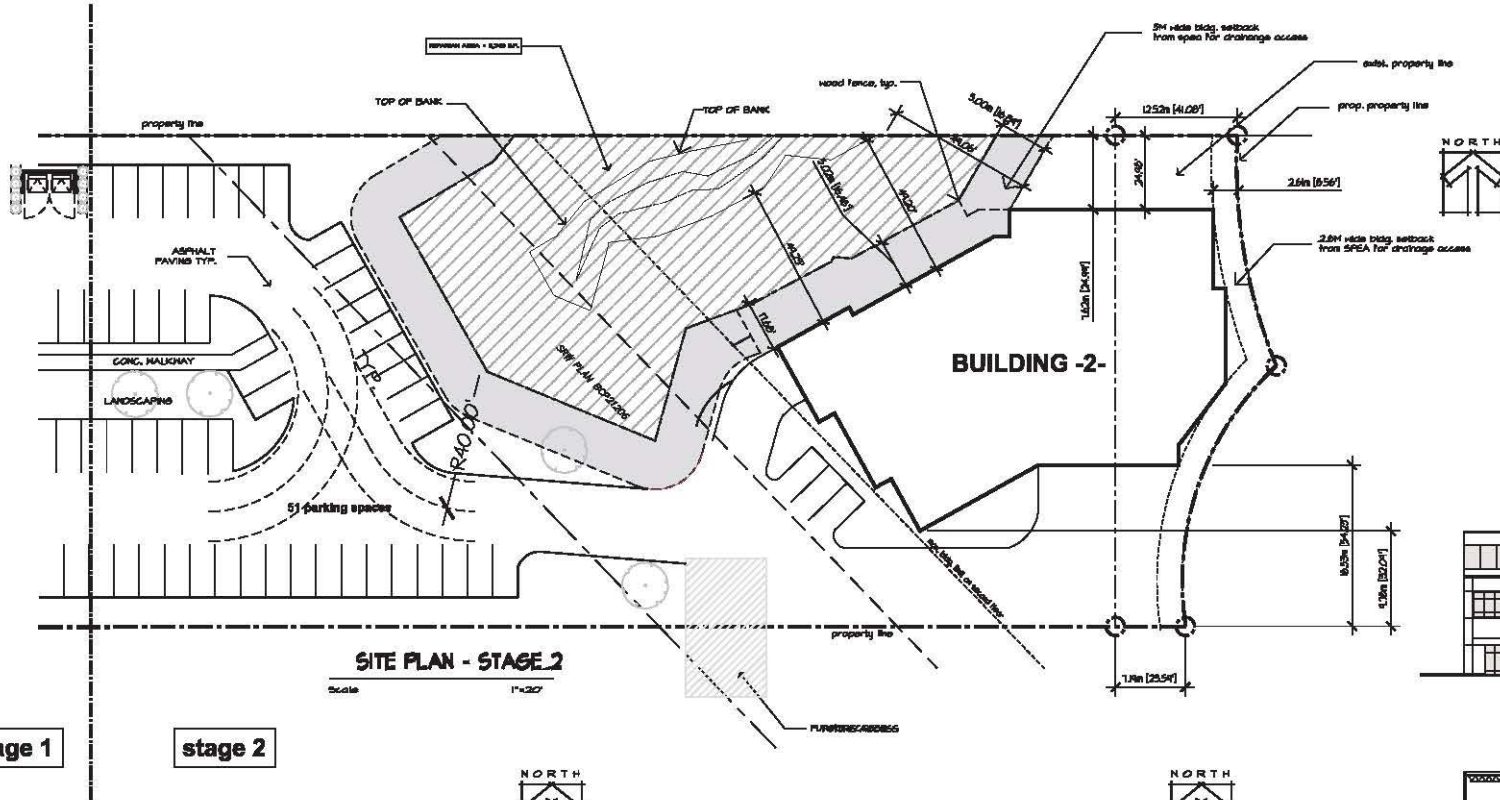

BUILDING - 2 - PARKING CALCULATION

ground floor - 5600 S.F. WAREHOUSE
 ground floor - 5000 S.F. WAREHOUSE
 second floor - 10600 S.F. OFFICE
 third floor - 10600 S.F. OFFICE

PARKING REQUIRED:

ground floor warehouse - 5600/700 = 8 spaces
 ground floor office - 5000/700 = 7 spaces
 2nd floor office - 10600 / 700 x 0.25 = 37.9 spaces
 3rd floor office - 10600 / 700 x 0.25 = 37.9 spaces
 total parking required = 91 spaces

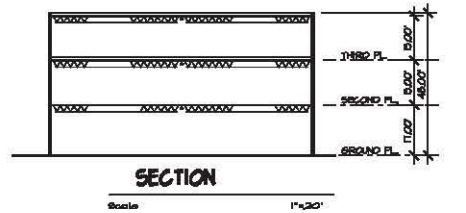
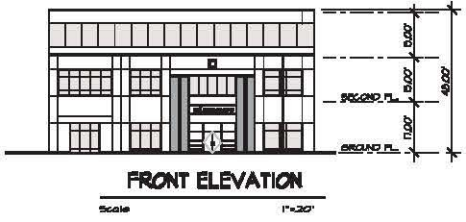

stage 1 stage 2

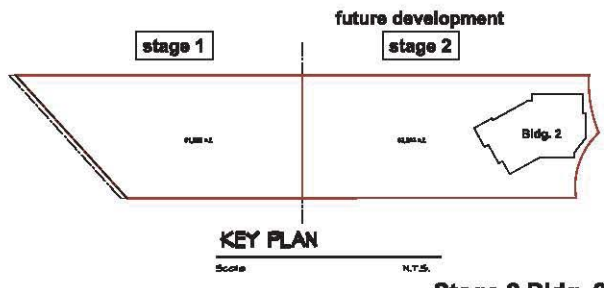
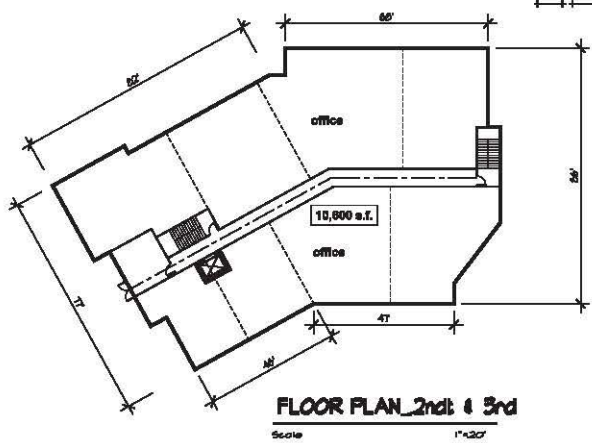
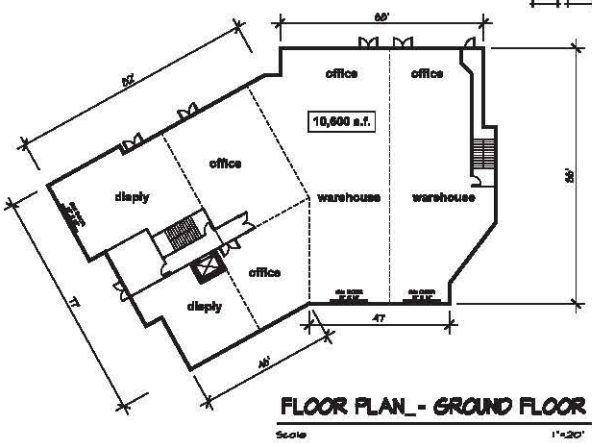

Rev	Date	Description
01	08-06-17	ISSUED FOR IDP
02	08-23-17	ISSUED FOR IDP SUBMISSION
03	08-23-17	ISSUED FOR IDP SUBMISSION
04	08-23-18	ISSUED FOR IDP SUBMISSION

Ionic Architecture Inc.
 architect - member a.i.a.a.
 3032 Croydon Drive
 Surrey, BC

Project Name	DETAILED SITE PLAN
Client	PROPOSED COMMERCIAL BUILDING
Project No.	15-1530
Sheet No.	SK-1

Stage 2 Bldg. 2 PRELIMINARY

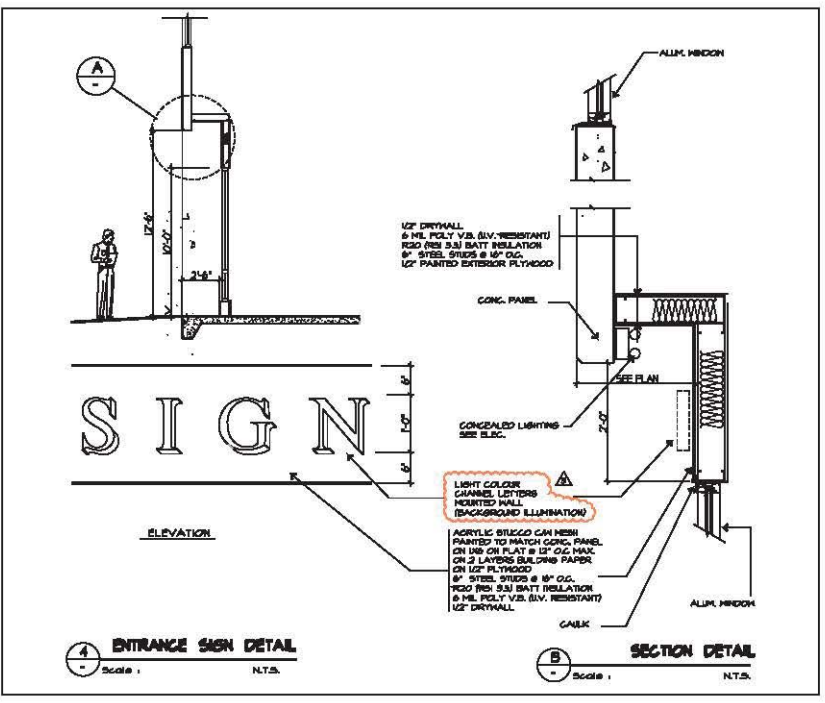
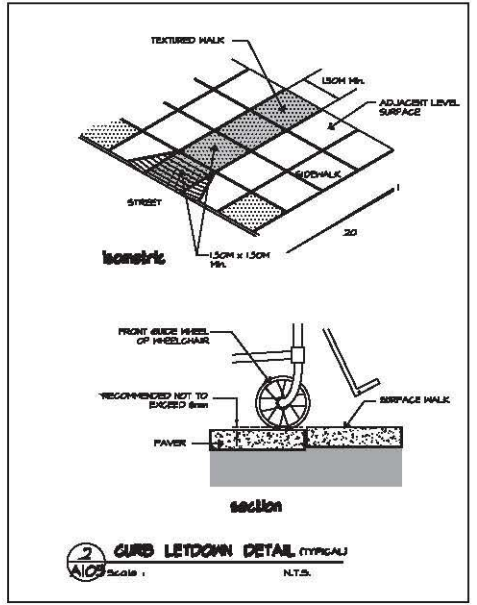
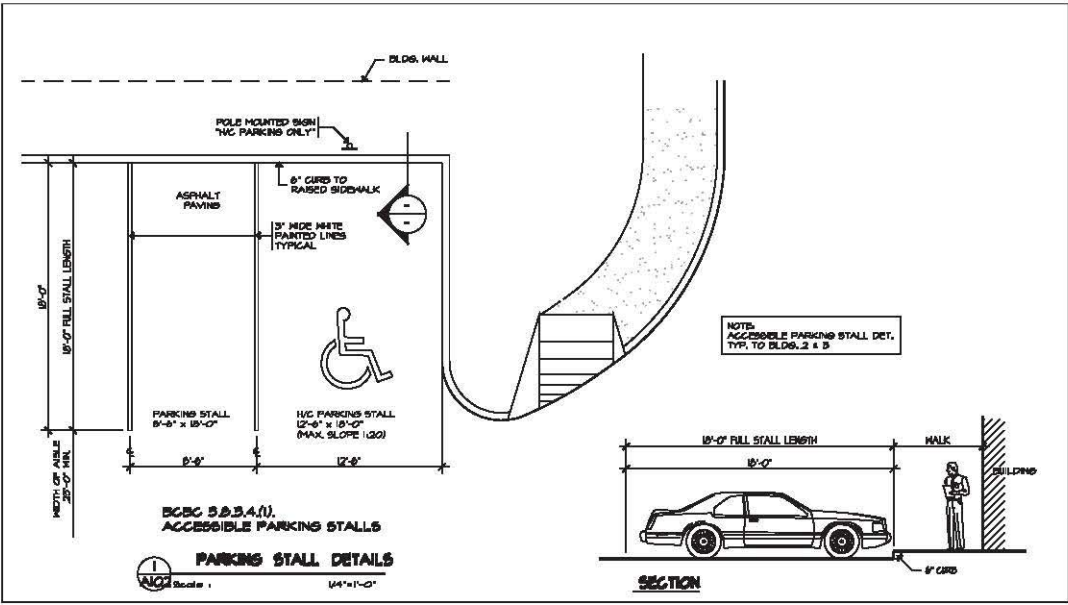

Revised	As Noted	Sheet	of	Project No.	15-1530
Date	SEP. 2016			Project Name	A401
Drawn				Proposed	COMMERCIAL BUILDINGS
				Address	3032 Croydon Drive Surrey, BC
Company Title			SITE DETAILS		
Ionic Architecture Inc.			architect - member a.i.b.c.		
ISSUED FOR SUBMISSION			ISSUED FOR SUBMISSION		
03 08-23-17			02 04-07-17		
02 04-07-17			01 08-23-16		
01 08-23-16			01 08-23-16		
Drawn By			Date		

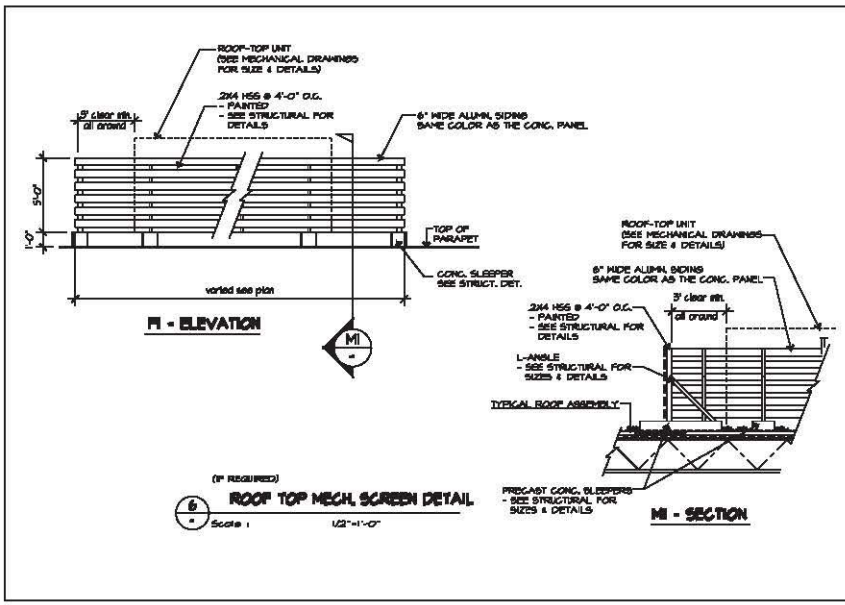
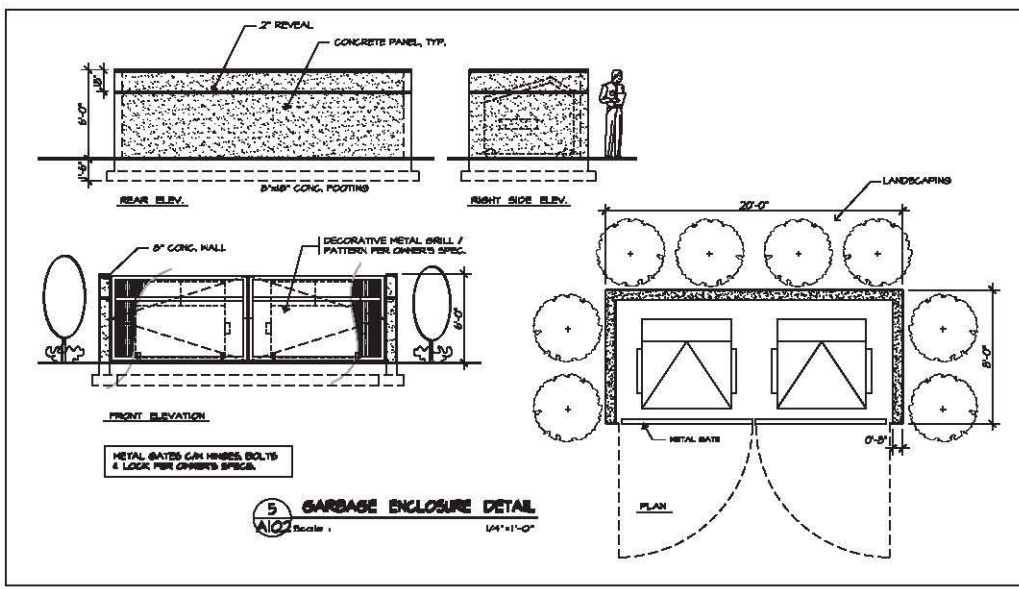

Project No.	15-1530	Sheet	A402
Date	SEP. 2016	Project Name	PROPOSED COMMERCIAL BUILDINGS
Revision		Address	3032 Croydon Drive Surrey, BC
Drawn By		Company Name	Ionic Architecture Inc. architect - member a.i.b.c.
Checked By		Project No.	15-1530
Scale		Revision	01
Project No.	15-1530	Project Name	PROPOSED COMMERCIAL BUILDINGS
Address	3032 Croydon Drive Surrey, BC	Company Name	Ionic Architecture Inc. architect - member a.i.b.c.
Project No.	15-1530	Project Name	PROPOSED COMMERCIAL BUILDINGS
Address	3032 Croydon Drive Surrey, BC	Company Name	Ionic Architecture Inc. architect - member a.i.b.c.
Project No.	15-1530	Project Name	PROPOSED COMMERCIAL BUILDINGS
Address	3032 Croydon Drive Surrey, BC	Company Name	Ionic Architecture Inc. architect - member a.i.b.c.

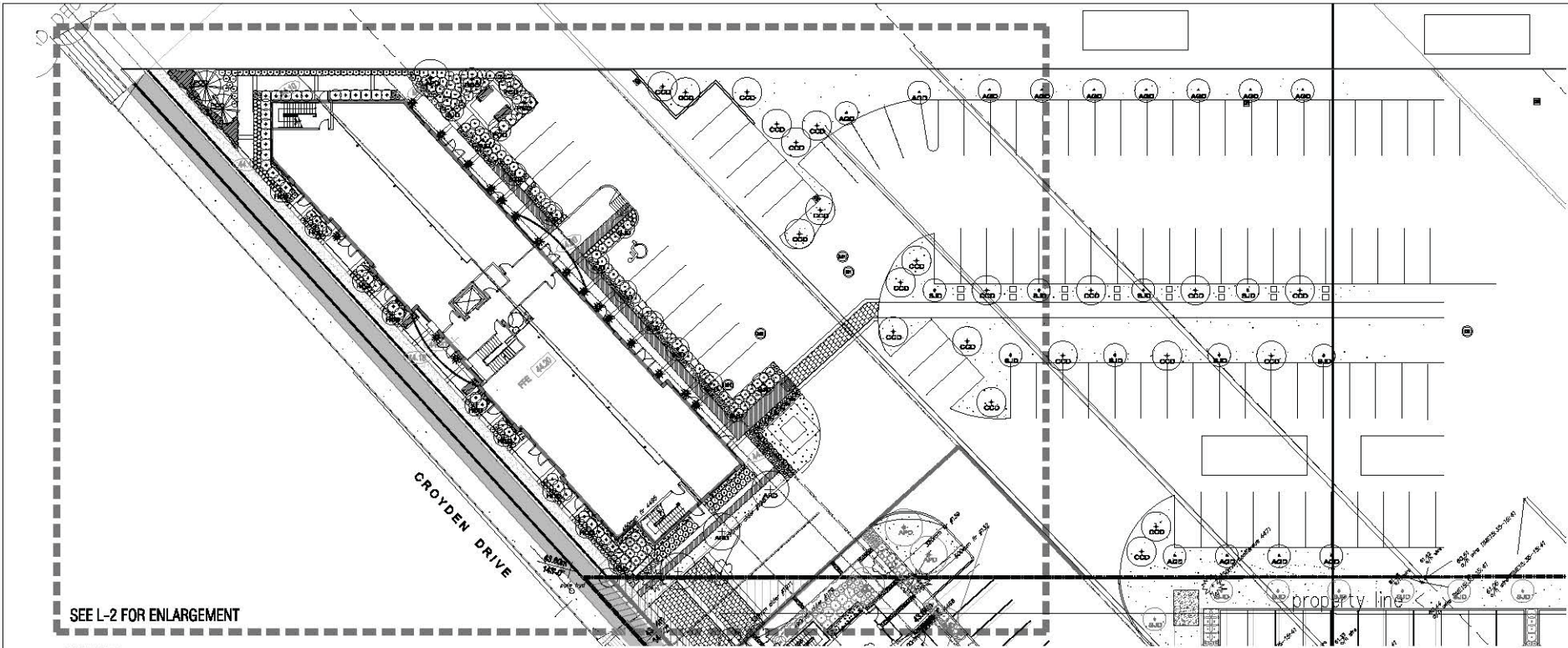

SEE L-2 FOR ENLARGEMENT



GENERAL LANDSCAPE NOTES

- ALL PLANT MATERIAL SHALL MEET OR EXCEED STANDARDS REQUIRED BY IBC/NA OR BC/CA GUIDELINES.
- TOPSOIL SUPPLIED SHALL BE FROM A REPUTABLE SOURCE. A FULL ANALYSIS OF THE TOPSOIL SHALL BE REQUIRED AT THE CONTRACTOR'S EXPENSE, SUBJECT TO LANDSCAPE CONSULTANT FOR APPROVAL.
- ANIMATE TOPSOIL PER SOIL ANALYSIS RECOMMENDATIONS FOR 10% SPREADING ON SITE. REJECTED TOPSOIL SHALL BE REMOVED OFF SITE IMMEDIATELY AT THE LANDSCAPE CONTRACTOR'S EXPENSE.
- TOPSOIL DEPTHS FOR PLANTING AS FOLLOWS:
 - GRASSED AREAS: 100MM
 - DRIVING CONCRES: 300MM
 - SHRUBS: 400MM
 - TREE PITS: 1000MM WITH 500MM (BELOW ROOT BALL)
- LOWM AREAS SHALL BE SOAKED WITH #1 FRESHWATER RESIDENTIAL COB.
- ALL SPRINK PLANTING AREAS SHALL HAVE GROUND COVERS 14" O.C.
- 2" DEPTH OF TANIUS COMPOST MULCH TO BE INSTALLED IN ALL SHRUB PLANTING AREAS.
- IRRIGATION SYSTEM - ALL MATERIALS SHALL BE RECLAIMED
- ROCK AND GRAVEL MATERIALS
 - ALL BOLLERS SHALL BE SMOOTH FINISH SOURCED FROM RIVER OR FIELD. DO NOT SUPPLY STRAIGHT OR SPLIT FACED STONE. THEY WILL BE REJECTED. PROVIDE 10% PHOTO OF STONE TO LANDSCAPE ARCHITECT FOR APPROVAL. BOLLERS TO BE EMBEDDED INTO GRADE 10' NET PER ON SURFACE.
 - FRONT TYPES AND MATERIALS AS FOLLOWS:
 - OFF SITE BOLLERS, CAST IN PLACE CONCRETE W/WOOD FINISH
 - ON SITE, CONCRETE AND WALKWAYS, CAST IN PLACE CONC. PAVING BROOK FINISH W/ EXPOSED AGGREGATE BAND.
- BENCHES: FINISHED ALUMINUM BENCHES — SECTER SA, 18" X 12" LONG, IPE WOOD. ALL METAL COMPONENTS TO BE POWDER COATED WITH BRANDED COLOUR FINISH.
- POTS: AVAILABLE FROM NORTHWEST LANDSCAPE SUPPLY 405-435-4142
 - MODEL COLUMN VALVE: 18" SP X 18" SP X 18" SP 70 LBS
 - TWIN NUMBER OF 4000
- SITE FENCING: WOOD ENVIRONMENTAL FENCE
- ROAD SIGNAGE AND OVERALL SITE SIGNING BY CIVIL ENGINEERING OR ARCHITECTURAL.
- STREET TREE SELECTION AND LOCATION TO BE DETERMINED BY CITY OF SLUICHT.

PLANT LIST:

REV	QTY	BOTANICAL NAME	COMMON NAME	SIZE	COND.
TREES					
AFD	1	ACER PALMATUS	JAPANESE MAPLE	3.0M HT.	B & B (SMALL-STEM)
ABD	3	ACER BIRMINGHAMENSE	BIRMINGHAM RED MAPLE	6 CM CAL.	B & B
ABD	15	ACER BIRNOLA COMPACTUM	COMPACT AMUR MAPLE	5 CM CAL.	B & B
CCD	11	ACER CANADENSE ACE OF HEAVEN	ACE OF HEAVEN REDBUD	5 CM CAL.	B & B
PCD	2	ACER SACHINENSIS	SACHIN SPICE	3.0M HT.	B & B
SD	25	BIOTEA JAPONICA CAMELLION	JAPANESE SHAWBELL	5 CM CAL.	B & B
SHRUBS					
ACD	9	BERBERIS DELICATA	SHRUBBY ALTHOA	2.0M HT.	B & B
PCD	4	FRAXINUS CORYMBOSA	FRAXINUS "BIRD CHERRY"	5 CM CAL.	B & B
TOC	18	TRILIX OCCIDENTALIS (SAMPAGNE)	GENERAL GREEN CEDAR	1.75M HT.	B & B
AZ	24	AZALEA JAPONICA GUMPO FINE	PINK AZALEA	40	CONTAINER
BM	27	BALUS MICROPHYLLA WINTER GEM	WINTER GEM BURNING	40	CONTAINER
CS	11	CORULUS SYLVESTRIS	RED OAKER DOORWOOD	40	CONTAINER
CT	8	CORONILLA TERRA	MEXICAN LUCK ORANGE	40	CONTAINER
PF	7	POTENTILLA FRUTICOSA	SHRUBBY GONOLISTOL	40	CONTAINER
PH	16	POLYDRUM MUNITZII	WESTERN GARDEN FERN	40	CONTAINER
PH	16	PHYSCOCARPUS OBLIVIFOLIS	MINESWICK	40	CONTAINER
PH	24	PHLOX DENDRON FACINMANNS FANTASTICA	FANTASTIC PHLOX DENDRON	40	CONTAINER
PH	10	RIBES VITIFOLIUM	WILD ROSE	40	CONTAINER
PH	15	RHODOCYPHON LIMULUS	LIMULUS RHODO	40	CONTAINER
SD	25	SYMPLOCARPOS COERCULATUS	CORNBERRY	40	CONTAINER
GROUND COVERS					
AL	52	ALEXANDERIA MARELLI	LADYS MANTLE	41	CONTAINER
AF	50	ANTHYMUS FULGIBERNA "GHOST"	LADY FERN	42	CONTAINER
CZ	74	CORDEPS VERTICILLATA ZAGNER	ZAGNER TICKSEED	41	CONTAINER
HB	107	HEMIPHYLLIS STELLA D'ORO	DAY LILY	41	CONTAINER
HE	15	HEDERA HELIX 'EMERALD QUEEN'	EMERALD QUEEN	41	CONTAINER
HC	100	HYPERICUM CALYCALUM	ST. JOHN'S WORT	10CM POT	CONTAINER
CA	27	CALAMAGROSTIS ACUTILOBA OVERDAM	VARIATED FEATHER REED GRASS	41	CONTAINER
PLANTS FOR POT					
AA	120	SEASONAL ANNUALS		10CM POT	CONTAINER

1 LANDSCAPE SITE PLAN - BUILDINGS 1 & PARKING LOT
SCALE 1/16"=1'-0"

LEGEND:

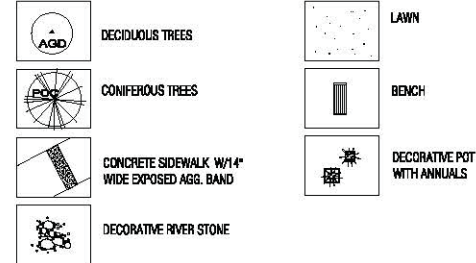

PROPOSED COMMERCIAL BUILDING
3032 CROYDEN DRIVE, SURREY, B.C.
ARCHITECT, LAND ARCHITECTURE INC.

PROJECT
PROPOSED COMMERCIAL BUILDING
3032 CROYDEN DRIVE, SURREY, B.C.
ARCHITECT, LAND ARCHITECTURE INC.

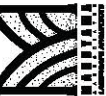

DATE	REVISED	BY	DATE	REVISED	BY
DESIGN		JL			
DRAWN		JL			
CHECKED		JL			
SCALE					
JOB NO.					

SHEET TITLE
LANDSCAPE SITE PLAN
OVERALL SITE
SHEET NO.
L-1

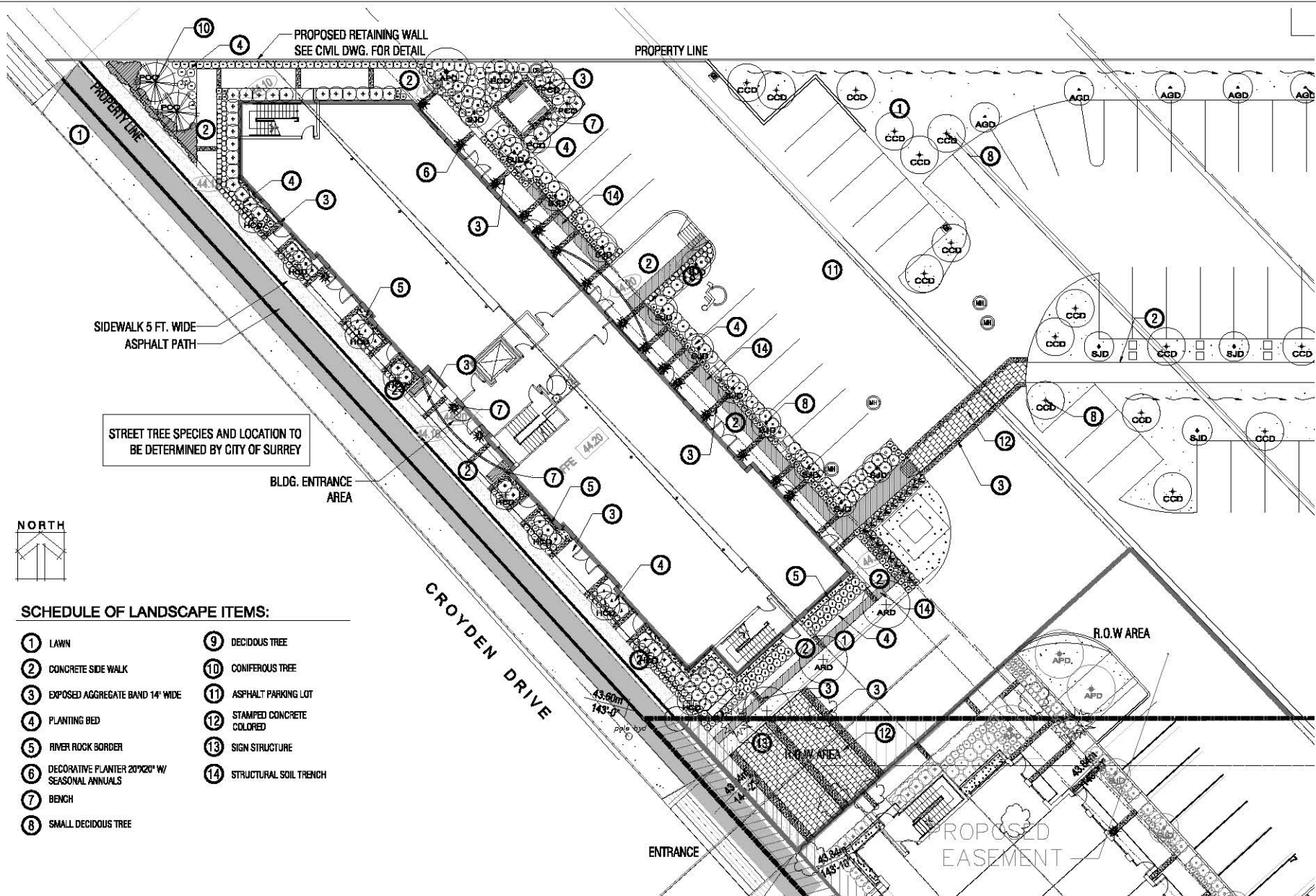

SCHEDULE OF LANDSCAPE ITEMS:

- | | |
|--|----------------------------|
| ① LAWN | ⑨ DECIDUOUS TREE |
| ② CONCRETE SIDE WALK | ⑩ CONIFEROUS TREE |
| ③ EXPOSED AGGREGATE BAND 14" WIDE | ⑪ ASPHALT PARKING LOT |
| ④ PLANTING BED | ⑫ STAMPED CONCRETE COLORED |
| ⑤ RIVER ROCK BORDER | ⑬ SIGN STRUCTURE |
| ⑥ DECORATIVE PLANTER 20"x20" W/ SEASONAL ANNUALS | ⑭ STRUCTURAL SOIL TRENCH |
| ⑦ BENCH | |
| ⑧ SMALL DECIDUOUS TREE | |



1 LANDSCAPE PLAN - BUILDING 1
SCALE: 3/32"=1'-0"

PREPARED BY: [Name] DATE: [Date]
 CHECKED BY: [Name] DATE: [Date]
 DRAWN BY: [Name] DATE: [Date]
 DESIGN BY: [Name] DATE: [Date]

PROJECT
PROPOSED COMMERCIAL BUILDING
 3032 CROYDEN DRIVE, SURREY, B.C.
 ARCHITECT: KANE ARCHITECTURE INC.
 Building Permit No. [Number]
 REG. NO. [Number]

DATE **NO. / REV.**
DESIGN **DATE**
DRAWN **DATE**
CHECKED **DATE**
SCALE **BY**
JOB NO. **DATE**

SHEET TITLE
LANDSCAPE PLAN
BUILDING 1
SHEET NO.
L-2

TO: **Manager, Area Planning & Development
- South Surrey Division
Planning and Development Department**

FROM: **Development Services Manager, Engineering Department**

DATE: **May 23, 2017** PROJECT FILE: **7815-0185-00**

RE: **Engineering Requirements
Location: 3032 Croydon Drive**

OCP AMENDMENT

There are no engineering requirements relative to the OCP Amendment beyond the items listed below.

REZONE/SUBDIVISION

Property and Right-of-Way Requirements

- Dedicate 1.883 m on Croydon Drive for ultimate 22.0m Collector Road standard.
- Register 1.6 m wide Statutory Right-of-Way (SRW) for the Pioneer Greenway along Croydon Drive.
- Register 2.6 m and 5.0 m wide SRWs along stream side corridors.
- Provide access easements for the adjacent lands to south and to north.

Works and Services

- Construct east side of Croydon Drive to Collector Road standard with 12.2 m pavement.
- Construct on Croydon Drive, the Pioneer Greenway/Multi-use Pathway.
- Construct 7.3 m wide concrete letdown.
- Construct storm drainage systems to service the site and the frontage road.
- Provide onsite sustainable drainage works and onsite detention to meet the NCP requirements.
- Extend a 300 mm water main on Croydon Drive.
- Provide water, sanitary and storm service connections for the development.

A Servicing Agreement is required prior to Rezone/Subdivision.

DEVELOPMENT PERMIT/DEVELOPMENT VARIANCE PERMIT

There are no engineering requirements relative to issuance of the Development Permit/Development Variance Permit beyond those noted above.



Rémi Dubé, P.Eng.
Development Services Manager

IK1

TREE PRESERVATION SUMMARY

Surrey Project No.: 7915-0185-00
 Project Address: 3032 Croydon Dr Surrey, BC
 Consulting Arborist: Nick McMahon

ON-SITE TREES:	QUANTITY OF TREES
Total Bylaw Protected Trees Identified (on-site trees including shared trees, plus trees within road boulevards - excluding trees within Park and ESA dedications)	46
Bylaw Protected Trees to be Removed	46
Bylaw Protected Trees to be Retained (excludes trees in Park dedication areas and ESA's)	0
Replacement Trees Required:	
Alder and Cottonwood at 1:1 ratio: 27 times 1 = 27	
All Other Bylaw Protected Trees at 2:1 ratio: 19 times 2 = 38	
TOTAL:	65
Replacement Trees Proposed	54
Replacement Trees in Deficit	11
Protected Trees Retained in Proposed Open Space/ Riparian Areas	10

OFF-SITE TREES:	QUANTITY OF TREES
Bylaw Protected Off-Site Trees to be Removed	4
Replacement Trees Required:	
Alder and Cottonwood at 1:1 ratio: 0 times 1 = 0	
All Other Bylaw Protected Trees at 2:1 ratio: 4 times 2 = 8	
TOTAL:	8
Replacement Trees Proposed	0
Replacement Trees in Deficit	8

NA denotes information "Not Available" at this time.

This summary and the referenced documents are prepared and submitted by:

 Nick McMahon, Consulting Arborist Dated: June 1, 2017

Direct: 604 812 2986
 Email: nick@aclgroup.ca

CITY OF SURREY

(the "City")

DEVELOPMENT VARIANCE PERMIT

NO.: 7915-0185-00

Issued To: ROSEMARY BUSINESS PARK LTD.

(the "Owner")

Address of Owner: 15272 - Croydon Drive, Unit 201
Surrey, BC V3S 0Z5

- 1. This development variance permit is issued subject to compliance by the Owner with all statutes, by-laws, orders, regulations or agreements, except as specifically varied by this development variance permit.
- 2. This development variance permit applies to that real property including land with or without improvements located within the City of Surrey, with the legal description and civic address as follows:

Parcel Identifier: 011-419-920
 Parcel "A" (M26060E) Lot 3 Section 23 Township 1 New Westminster District Plan 9266
 3032 - Croydon Drive

Parcel Identifier: 028-916-786
 Lot 2 Section 23 Township 1 New Westminster District Plan BCP51422
 3035 - 156 Street

(the "Land")

- 3. (a) As the legal description of the Land is to change, the City Clerk is directed to insert the new legal description for the Land once title has been issued, as follows:

Parcel Identifier:

- (b) If the civic address changes, the City Clerk is directed to insert the new civic address for the Land, as follows:

4. Surrey Zoning By-law, 1993, No. 12000, as amended is varied as follows:
 - (a) In the table in Section B.1 of Part 7A "Streamside Protection", the minimum setback measured from top-of-bank for a "Natural Class B Stream" is reduced from 15 metres (49 ft.) to 10 metres (33 ft.), at the closest point, along the north lot line of the subject property.
5. This development variance permit applies to only the portion of the Land shown on Schedule A which is attached hereto and forms part of this development variance permit. This development variance permit does not apply to additions to, or replacement of, any of the existing buildings shown on attached Schedule A, which is attached hereto and forms part of this development variance permit.
6. The Land shall be developed strictly in accordance with the terms and conditions and provisions of this development variance permit.
7. This development variance permit shall lapse if the Owner does not substantially start any construction with respect to which this development variance permit is issued, within two (2) years after the date this development variance permit is issued.
8. The terms of this development variance permit or any amendment to it, are binding on all persons who acquire an interest in the Land.
9. This development variance permit is not a building permit.

AUTHORIZING RESOLUTION PASSED BY THE COUNCIL, THE DAY OF , 20 .
ISSUED THIS DAY OF , 20 .

Mayor – Linda Hepner

City Clerk – Jane Sullivan



Proposed variance to the minimum setback from top-of-bank from 15 metres (49 ft.) to 10 metres (33 ft.), to the closest point, for a Class B watercourse

- Site Boundary
- Surveyed Top of Bank
- Surveyed High Water Mark
- Detailed RAR SPEA
- Dimensions
- Proposed Setback (10m from TOB)
- 15m Streamside Setback
- Class B Stream (Surrey Streamside Protection Classification)

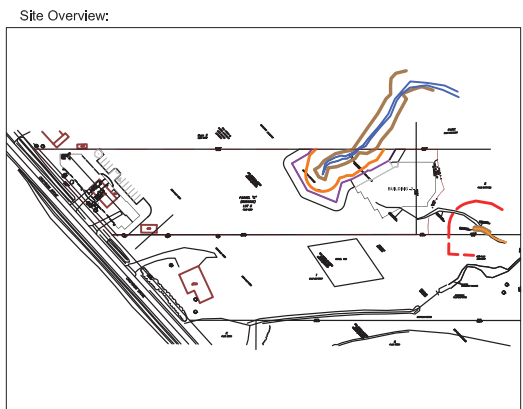

Summary RAR Assessment SPEA & Streamside Setback Map			
Rosemary Business Park Ltd. 3032 Croydon Drive, Surrey, BC		PHOENIX ENVIRONMENTAL SERVICE 505 - 175 W. Broadway, Vancouver Tel. 604.689.3888 Fax. 604.689.38	
DATE: June 6, 2017	DRAWN BY: NGL	SCALE: As Shown	DWG: Croydon.RAR.Setbacks.dwg

Schedule A

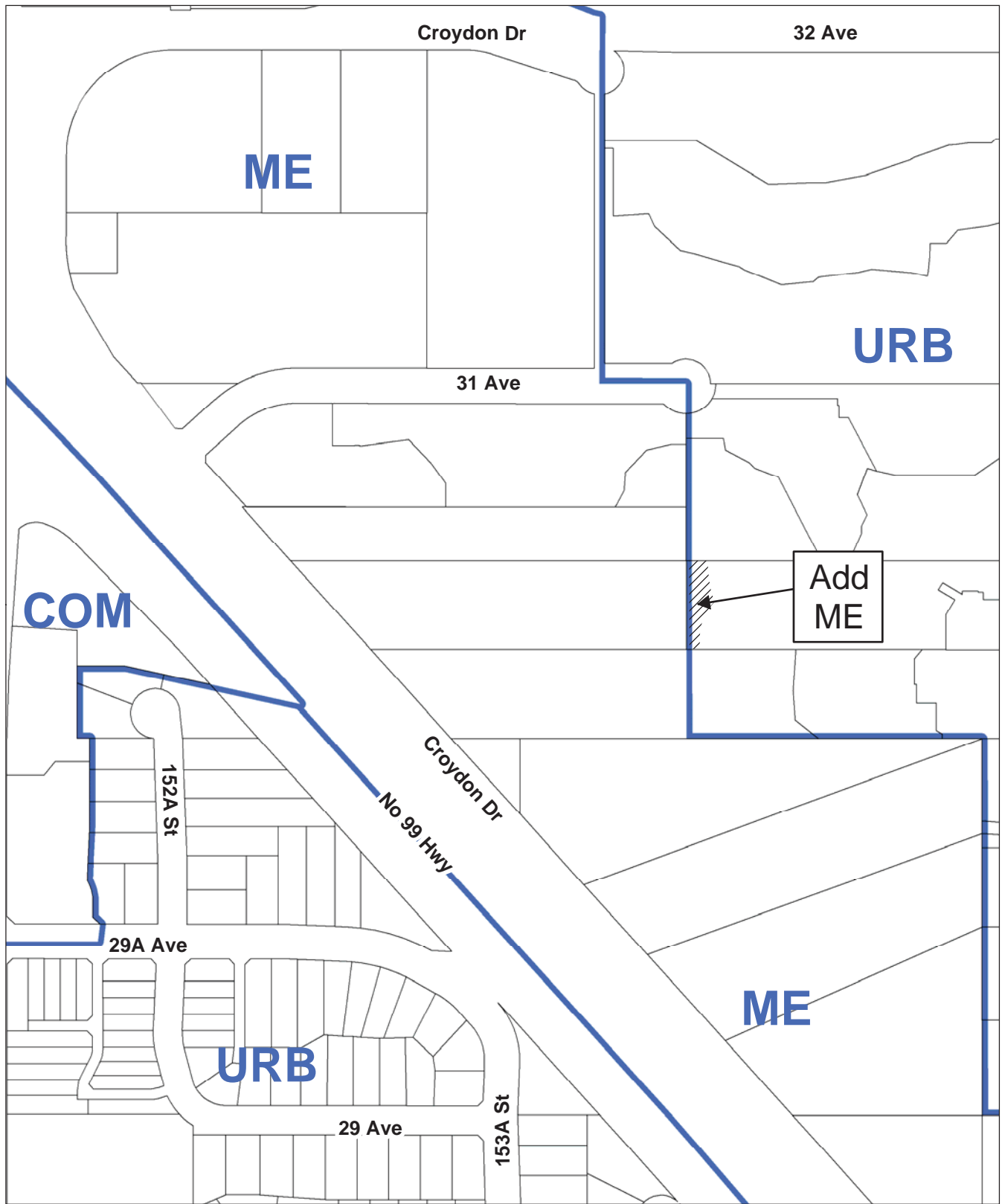

OCP Amendment 7915-0185-00
Proposed amendment by adding a Mixed
Employment designation in Figure 42: Major
Employment Areas



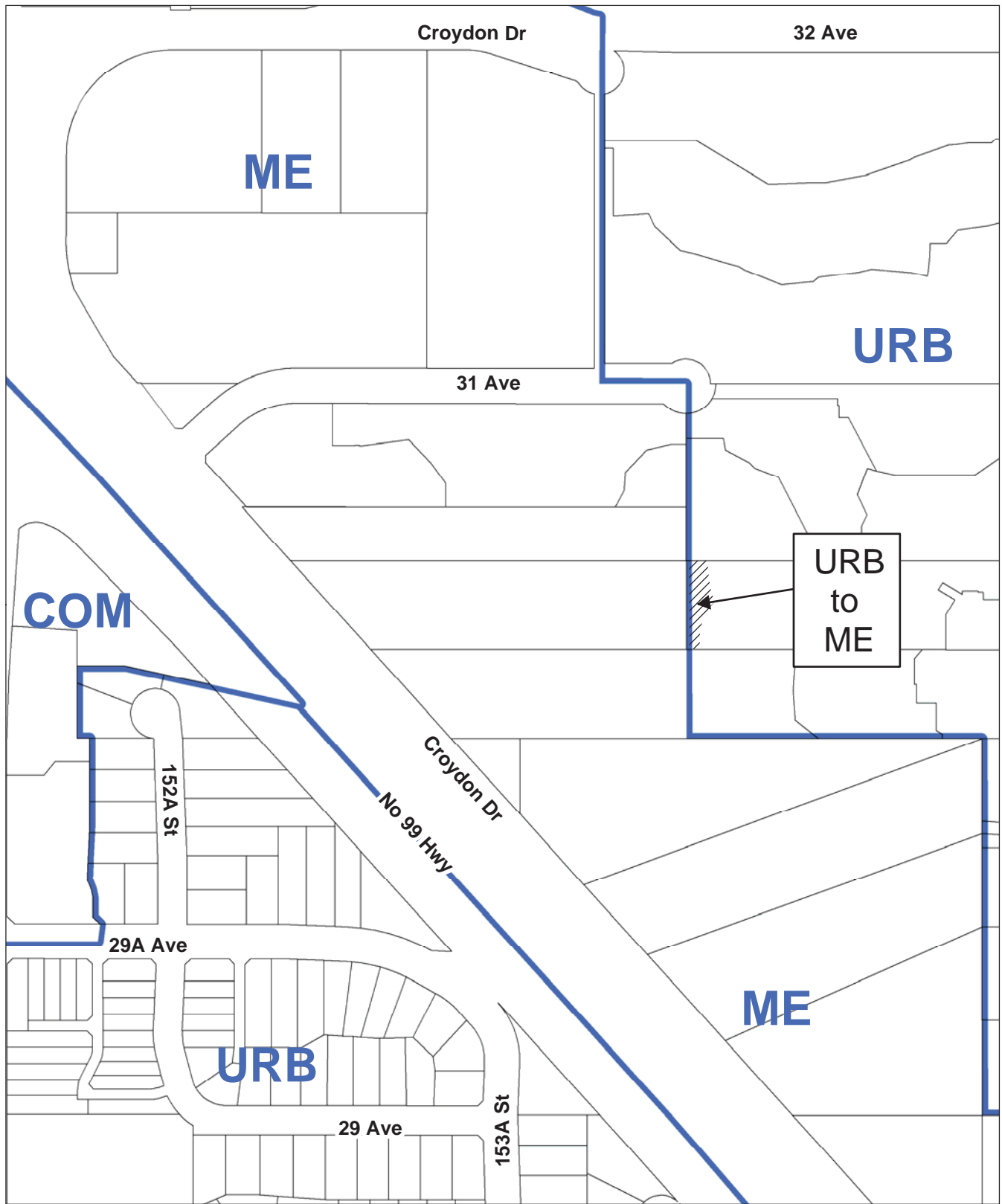

OCP Amendment 7915-0185-00
 Proposed amendment from Urban to Mixed
 Employment in Figure 3: General Land Use
 Designations



CITY OF SURREY

BYLAW NO. _____

A by-law to amend Surrey Zoning By-law, 1993, No. 12000, as amended

.....

THE CITY COUNCIL of the City of Surrey ENACTS AS FOLLOWS:

1. Surrey Zoning By-law, 1993, No. 12000, as amended, is hereby further amended, pursuant to the provisions of Section 479 of the Local Government Act, R.S.B.C. 2015 c. 1, as amended by changing the classification of the following parcels of land, presently shown upon the maps designated as the Zoning Maps and marked as Schedule "A" of Surrey Zoning By-law, 1993, No. 12000, as amended as follows:

- (a) FROM: ONE-ACRE RESIDENTIAL ZONE (RA)
- TO: COMPREHENSIVE DEVELOPMENT ZONE (CD)

Parcel Identifier: 011-419-920
 Parcel "A" (M26060E) Lot 3 Section 23 Township 1 New Westminster District Plan 9266
 3032 - Croydon Drive

- (b) FROM: BUSINESS PARK ZONE (IB)
- TO: COMPREHENSIVE DEVELOPMENT ZONE (CD)

Portion of Parcel Identifier: 028-916-786
 Lot 2 Section 23 Township 1 New Westminster District Plan BCP51422

as shown on the Survey Plan attached hereto and forming part of this Bylaw as Schedule A, certified correct by James E. Enders, B.C.L.S. on the 19th day of May, 2017, containing 572.3 square metres, called Block B.

Portion of 3035 - 156 Street

(hereinafter both 1.(a) and (b) shall be referred to as the "Lands")

2. The following regulations shall apply to the *Lands*:

A. Intent

This Comprehensive Development Zone is intended to accommodate and regulate the development of a business park consisting of *light impact industrial* uses, office uses and limited service uses in a *comprehensive design* where *density bonus* is provided.

B. Permitted Uses

The *Lands* and *structures* shall be used for the following uses only, or for a combination of such uses:

1. *Light impact industry.*
2. *Warehouse uses.*
3. *Distribution centres.*
4. Office uses excluding *social escort services* and *methadone clinics*.
5. *Accessory uses* including the following:
 - (a) *Eating establishments*, excluding *drive-through restaurants*, provided that:
 - i. The *eating establishment* does not exceed a *gross floor area* of 200 square metres [2,150 sq. ft.];
 - ii. The *eating establishment* accommodates a maximum of 100 seats; and
 - iii. A maximum of one *eating establishment* with a *gross floor area* greater than 150 square metres [1,600 sq. ft.] on the *lot* and where a *lot* has been subdivided by a strata plan then there shall only be one *eating establishment* with a *gross floor area* greater than 150 square metres [1,600 sq. ft.] within the strata plan;
 - (b) *Personal service uses* limited to the following:
 - i. Barbershops;
 - ii. Beauty parlours;
 - iii. Cleaning and repair of clothing; and
 - iv. Shoe repair shops;
 - (c) *General service uses* excluding *drive-through banks*;

- (d) *Community services;*
- (e) *Child care centres;* and
- (f) *Assembly halls* limited to *churches*, provided that:
 - i. The *church* does not exceed a *gross floor area* of 700 square metres [7,500 sq. ft.];
 - ii. The *church* accommodates a maximum of 300 seats; and
 - iii. There is not more than one *church* on a *lot* and where a *lot* has been subdivided by a strata plan, there shall be only one *church* within the strata plan.

C. Lot Area

Not applicable to this Zone.

D. Density

- 1. The *floor area ratio* shall not exceed 0.10 but may be increased to 1.09 if amenities are provided in accordance with Schedule G of Surrey Zoning By-law, 1993, No. 12000, as amended.

E. Lot Coverage

The *lot coverage* shall not exceed 46%.

F. Yards and Setbacks

Buildings and *structures* shall be sited in accordance with the following minimum *setbacks*:

Use	Setback <i>North Yard</i>	<i>South Yard</i>	<i>East Yard</i>	<i>West Yard</i>
<i>Principal Buildings</i>	7.5 m.*	9.5 m.**	2.6 m.	2.9 m.
<i>Accessory Buildings and Structures</i>	[25 ft.]	[31 ft.]	[9 ft.]	[10 ft.]

Measurements to be determined as per Part 1 Definitions of Surrey Zoning By-law, 1993, No. 12000, as amended.

* The north *yard* setback may be reduced to 2.9 metres [10 ft.] at the northwest corner of the *Lands*.

** The south *yard* setback may be reduced to 2.9 metres [10 ft.] at the southwest corner of the *Lands*.

G. Height of Buildings

Measurements to be determined as per Part 1 Definitions of Surrey Zoning By-law, 1993, No. 12000, as amended.

1. *Principal buildings*: The *building height* shall not exceed 14.6 metres [48 ft.].
2. *Accessory buildings and structures*: The *building height* shall not exceed 6 metres [20 ft.].

H. Off-Street Parking

1. Refer to Table C.1 of Part 5 Off-Street Parking and Loading/Unloading of Surrey Zoning By-law, 1993, No. 12000, as amended.
2. *Tandem parking* may be permitted for company fleet vehicles.

I. Landscaping

1. All developed portions of the *lot* not covered by *buildings, structures* or paved areas shall be landscaped including the retention of mature trees. This *landscaping* shall be maintained.
2. Along the developed sides of the *lot* which abut a *highway*, a continuous *landscaping* strip of not less than 1.5 metres [5 ft.] in width shall be provided from back of curb or projected future curb location, except at *driveways* and adjacent to *buildings*.
3. The boulevard areas of *highways* abutting a *lot* shall be seeded or sodded with grass on the side of the *highway* abutting the *lot*, except at *driveways*.

J. Special Regulations

1. *Land* and *structures* shall be used for the uses permitted in the Zone only if such uses:
 - (a) Constitute no unusual fire, explosion or safety hazard;
 - (b) Do not emit noise in excess of 60 dB measured at any point on any boundary of the *lot* on which the use is located; and
 - (c) Do not produce heat or glare perceptible from any boundary of the *lot* on which the use is located.

2. Outdoor storage of any goods, materials or supplies is specifically prohibited.
3. Garbage containers and *passive recycling containers* shall not be located within any *front yard setback*.
4. *Child care centres* shall be located on the *lot* such that these centres have direct access to an *open space* and play area within the *lot*.

K. Subdivision

Lots created through subdivision in this Zone shall conform to the following minimum standards:

<i>Lot Size</i>	<i>Lot Width</i>	<i>Lot Depth</i>
0.75 hectare [1.85 acres]	50 metres [164 ft.]	150 metres [492 ft.]

Dimensions shall be measured in accordance with Section E.21 of Part 4 General Provisions of Surrey Zoning By-law, 1993, No. 12000, as amended.

L. Other Regulations

In addition to all statutes, bylaws, orders, regulations or agreements, the following are applicable, however, in the event that there is a conflict with the provisions in this Comprehensive Development Zone and other provisions in Surrey Zoning By-law, 1993, No. 12000, as amended, the provisions in this Comprehensive Development Zone shall take precedence:

1. Definitions are as set out in Part 1 Definitions of Surrey Zoning By-law, 1993, No. 12000, as amended.
2. Prior to any use, the *Lands* must be serviced as set out in Part 2 Uses Limited, of Surrey Zoning By-law, 1993, No. 12000, as amended and in accordance with the servicing requirements for the IB-3 Zone as set forth in the Surrey Subdivision and Development By-law, 1986, No. 8830, as amended.
3. General provisions are as set out in Part 4 General Provisions of Surrey Zoning By-law, 1993, No. 12000, as amended.
4. Additional off-street parking requirements are as set out in Part 5 Off-Street Parking and Loading/Unloading of Surrey Zoning By-law, 1993, No. 12000, as amended.
5. Sign regulations are as set out in Surrey Sign By-law, 1999, No. 13656, as amended.
6. Special *building setbacks* are as set out in Part 7 Special Building Setbacks, of Surrey Zoning By-law, 1993, No. 12000, as amended.

7. *Building* permits shall be subject to the Surrey Building Bylaw, 2012, No. 17850, as amended.
8. *Building* permits shall be subject to Surrey Development Cost Charge Bylaw, 2016, No. 18664, as may be amended or replaced from time to time, and the development cost charges shall be based on the IB-3 Zone.
9. Tree regulations are set out in Surrey Tree Protection Bylaw, 2006, No. 16100, as amended.
10. Development permits may be required in accordance with the Surrey *Official Community Plan* By-law, 2013, No. 18020, as amended.
11. Provincial licensing of *child care centres* is regulated by the Community Care and Assisted Living Act S.B.C. 2002, c. 75, as amended, and the Regulations pursuant thereto including without limitation B.C. Reg 319/89/213.

3. This By-law shall be cited for all purposes as "Surrey Zoning By-law, 1993, No. 12000, Amendment By-law, _____, No. _____."

PASSED FIRST READING on the _____ th day of _____, 20__ .

PASSED SECOND READING on the _____ th day of _____, 20__ .

PUBLIC HEARING HELD thereon on the _____ th day of _____, 20__ .

PASSED THIRD READING on the _____ th day of _____, 20__ .

RECONSIDERED AND FINALLY ADOPTED, signed by the Mayor and Clerk, and sealed with the Corporate Seal on the _____ th day of _____, 20__ .

_____ MAYOR

_____ CLERK

**SURVEY PLAN TO ACCOMPANY
CITY OF SURREY
REZONING BYLAW# _____ OF
PARCEL "A" (M2606E) LOT 3 PLAN 9266, AND
PART OF LOT 2 PLAN BCP51422,
BOTH OF SECTION 23 TOWNSHIP 1
NEW WESTMINSTER DISTRICT**

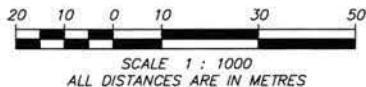

CERTIFIED CORRECT ACCORDING TO SURVEY
DATED THIS 19th DAY OF MAY, 2017.

James R. Enders
JAMES R. ENDERS, BCLS 659

MURRAY & ASSOCIATES
PROFESSIONAL LAND SURVEYORS
201-12448 82nd AVENUE
SURREY, BC V3W 3E9
(604) 597-9189

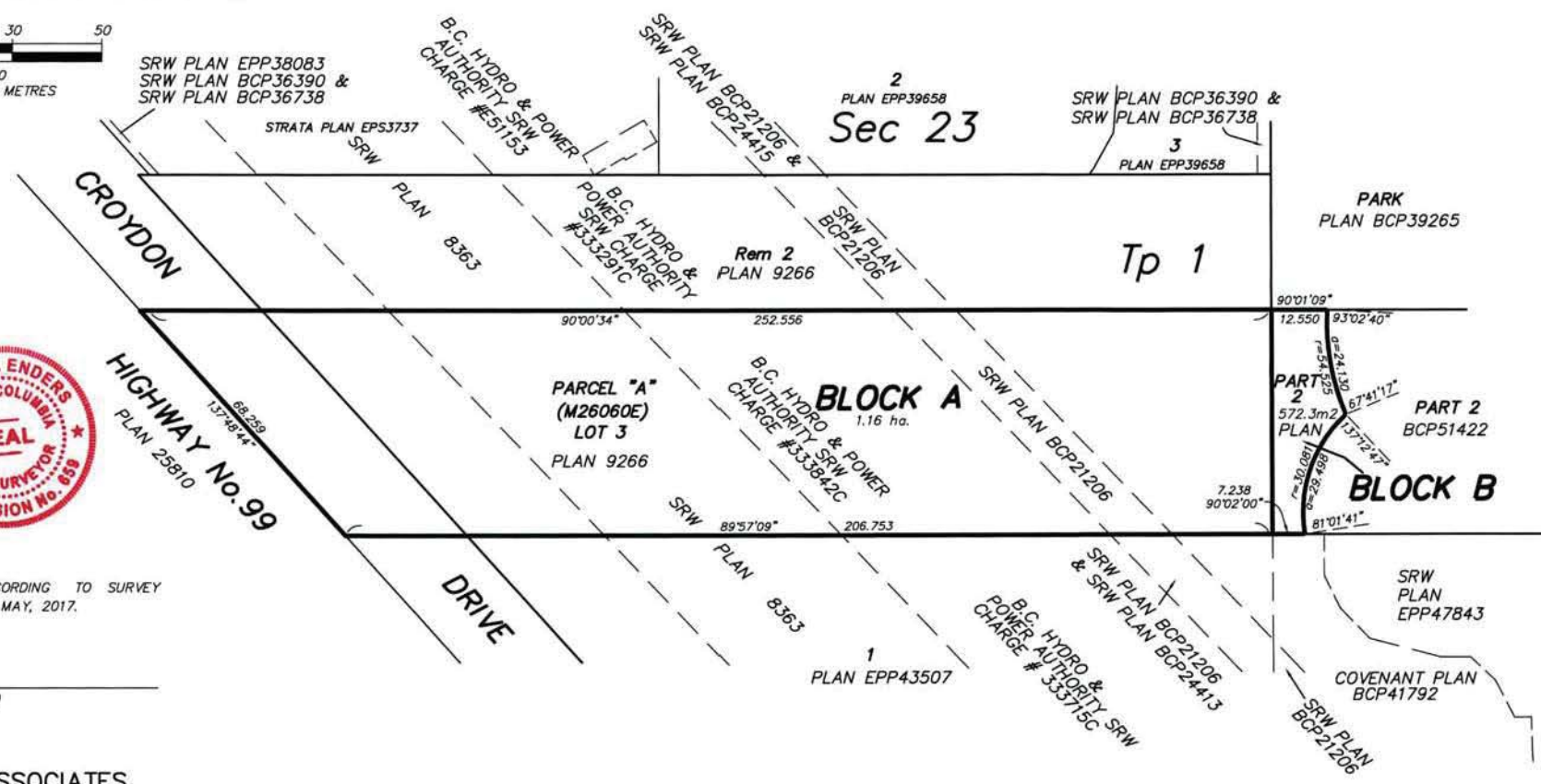

2
PLAN EPP39658
Sec 23

Tp 1

PARCEL "A"
(M2606E)
LOT 3
PLAN 9266

BLOCK A
1.16 ha.

BLOCK B

Schedule A

9275-BLOCK

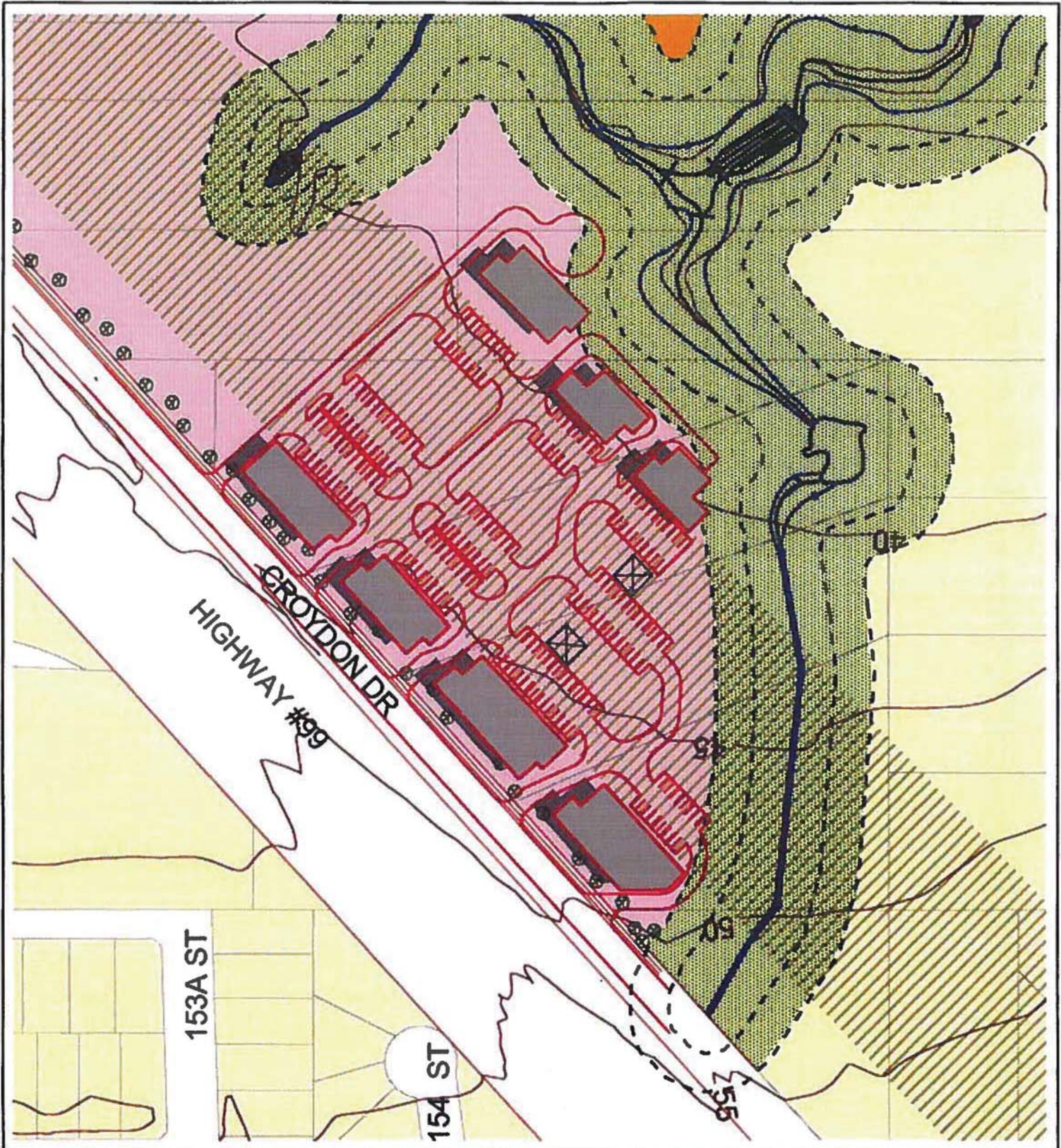

Rosemary Heights Business Park Proposed Land Use Plan

City of Surrey Planning & Development Department

NOTE: This plan is conceptual in nature and is only intended to reflect a general pattern of land use.

0 20 40 Meters

Figure #3

DATE Feb 4, 2000

LEGEND

Potential Site Design for
Business Park Development
Adjacent to Hydro Lines



SURREY
City of Surrey