



PROCUREMENT SERVICES

**CITY OF SURREY, SURREY CITY HALL
13450 – 104 Avenue, Surrey, B.C., V3T 1V8
Tel: 604-590-7274
E-mail: purchasing@surrey.ca**

ADDENDUM No. 1

REQUEST FOR QUOTATION No.: 1220-040-2024-041
TITLE: ARENA DIGITAL VIDEO SCREENS
ADDENDUM ISSUE DATE: JUNE 13, 2024
REVISED DATE: PREFER TO RECEIVE SUBMISSION ON OR BEFORE JUNE 21, 2024.

INFORMATION FOR CONTRACTORS

Contractors are advised that Addendum No. 1 to 1220-040-2024-041 is hereby issued by the City. This addendum shall form part of the contract documents and is to be read, interpreted and coordinated with all other parts. The following information is provided to answer questions raised by Contractors for the above-named project, to the extent referenced and shall become a part thereof. No consideration will be allowed for extras due to the Contractors or any sub-contractor not being familiar with this addendum. This Addendum No. 1 contains four (4) pages.

REVISED DATE:

Delete Section 3 in its entirety and substitute with Section 3 below:

3. DATE

The City would prefer to receive Quotations on or before **June 21, 2024** (the "Date").

CLARIFICATIONS:

- Add the following additional requirements on Section 2. Arena Digital LED Screen Equipment Requirements of Schedule A – Specifications of Goods and Scope of Services:**
 - The Contractor to hire a structural engineer to confirm the feasibility of attachment of the proposed locations.

- Contractor's structural engineer to confirm the installation method and design the supporting structure for screens attachment as per the manufacturer installation guide.
 - All electrical and data work required to install, test, and commission the new screens is to be included in the scope of this RFQ.
 - The Contractor will be responsible for obtaining all permits required to complete the work.
2. Refer to the cross sections drawing for the proposed location of the screens. All measurements are approximate and need to be confirmed onsite, but it appears that there is not enough space to install a 14' x 24' screen against the wood walls on each side of attic cages.

Drawings may be viewed and/or obtained at the Managed File Transfer Service (MFT) link noted below. Printing will be the sole responsibility of the Contractor.

In the URL, or address field at the top, enter the following address: <https://mft.surrey.ca/> and hit "enter".

Enter "surreybid" as the Username, "Welcome" as the password and then click "Login"

<https://mft.surrey.ca/>

Login ID: surreybid

Password: Welcome

Folder: 1220-040-2024-041

QUESTIONS AND ANSWERS:

Q1. Please provide more information about the existing structure (if any) and how to fasten our mounting structure to support the screens.

A1. Please access the drawings.

Q2. Site Plans are required to plan staging and measurements for Data. Is a Site plan of the property available?

A2. Please access the drawings.

Q3. Elevation drawings and cross section drawings. This will be required for Engineering stamps, and we cannot obtain attachment details or engineering of the digital sign without.

A3. Please access the drawings.

Q4. Engineer copies of the building drawings, wooden beams or walls will be required by our engineering team to confirm and review weight and loading of attachment.

A4. Please access the drawings.

Q5. Electrical power draw will be required and increased to the panels. Is there an on site electrician that will be providing power to the signage? If they are to provide power, is it possible for them to also run Data at the same time in a separate conduit (this could save a lot of money).

A5. Currently we are exploring power and data requirements.

Q6. Onsite storage available for lift equipment, or safe place to park it on premise?

A6. During installation onsite storage of lifts and equipment will be made available.

Q7. Would you be kind to confirm the fact that the 2 x Digital screens will be installed against the walls and if possible for us to send out our local certified Sign installers to have a look?

A7. Confirmed, two (2) digital screens against the wall. Yes an installer can visit the site as it's a public facility but we cannot guarantee anyone onsite will be able to answer any specific questions.

Q8. Can the electricians run the CAT6 cables from the media box?

A8. Yes.

Q9. What are the working hours available the contractor to complete the work during the week?

A9. Once a Contractor has been selected and a PO issued the City will work out an installation schedule.

Q10. What are the working hours available the contractor to complete the work on the weekends?

A10. Once a Contractor has been selected and a PO issued the City will work out an installation schedule.

Q11. What content management system does the client want to use?

A11. The City is open to options on Content Management Systems.

Q12. What is the floorboard system? Does it lock together? If the entire ice is not covered will it move? Can a scissor lift go on it?

A12. A scissor lift can go directly onto the ice.

Q13. Where is the LED sign going to be staged when it is delivered and while the work is being completed?

A13. City staff will work with the successful Contractor on site specific items such as storage and staging.

Q14. Can we wall mount the sign on the wood vertices?

A14. Please access the drawings.

Q15. How does the AC unit get accessed?

A15. The units on the East and West end are each accessed through a hatch through the ceiling on the east concourse and the meeting room ceiling on the west.

Q16. Can we hang the sign on the truss above the ice?

A16. Please access the drawings.

Q17. What is the intended use of the screen during minor hockey events?

A17. Digital advertising.

Q18. What's the intended use of the screen during JR A events?

A18. Game replay and digital advertising.

Q19. Can the minimum required bid spec of the LED be: Black face, copper wire, 1800 nits?

A19. Specifications are detailed in scheduled A, please note your specifications in your response in Schedule B.

Q20. Does the City only require HDMI/SDI inputs into the processor of the LED video screen?

A20. The preference is to use SDI due to distance, but HDMI works well too. The more connectors we have the greater versatility

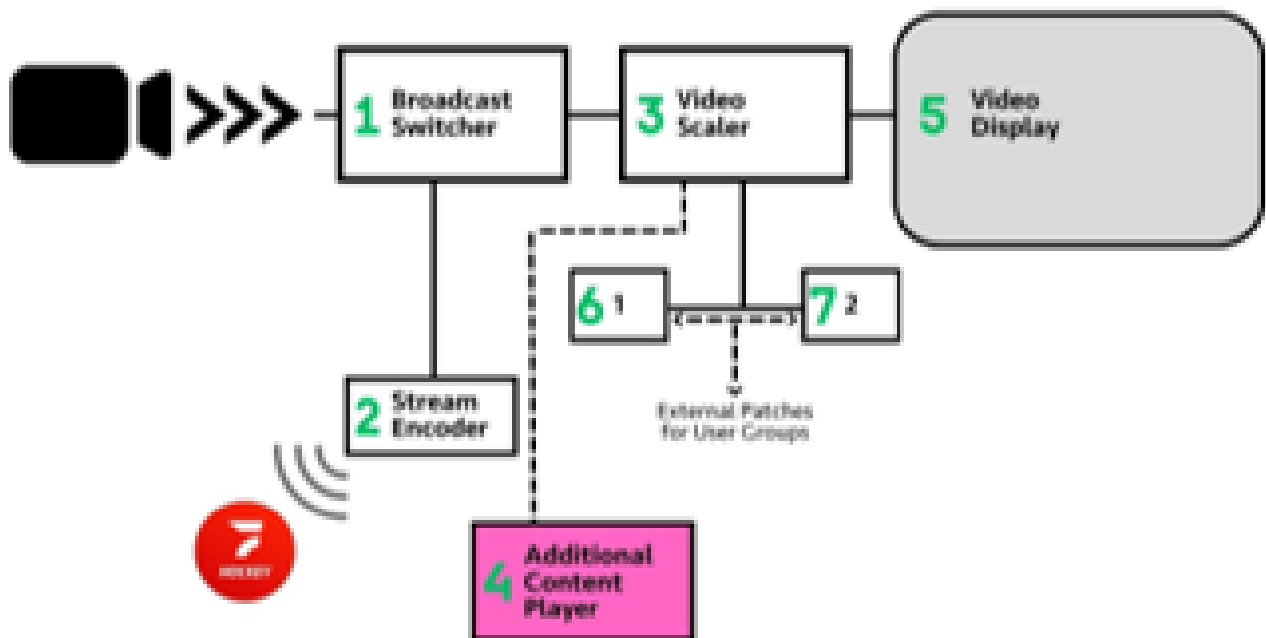

All Addenda will become part of the Contract Documents.
