

City of Surrey
PLANNING & DEVELOPMENT REPORT

File: 7913-0047-00

Planning Report Date: November 25, 2013

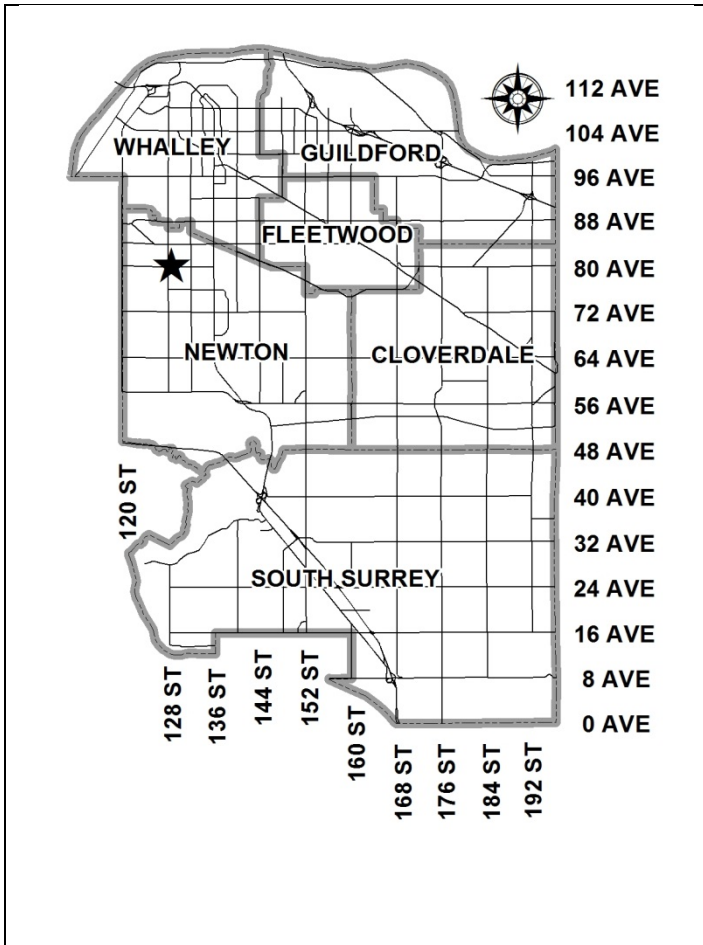

PROPOSAL:

- **OCP amendment** from Industrial to Commercial
- **Rezoning** from IL to CD (based on C-8)
- **Development Permit**

in order to permit the development of a 5-building retail commercial project.

LOCATION: 12829 - 80 Avenue
 8020 - 128 Street

OWNER: Muric Enterprises Ltd.

ZONING: IL

OCP DESIGNATION: Industrial

LAP DESIGNATION: High Impact Industrial

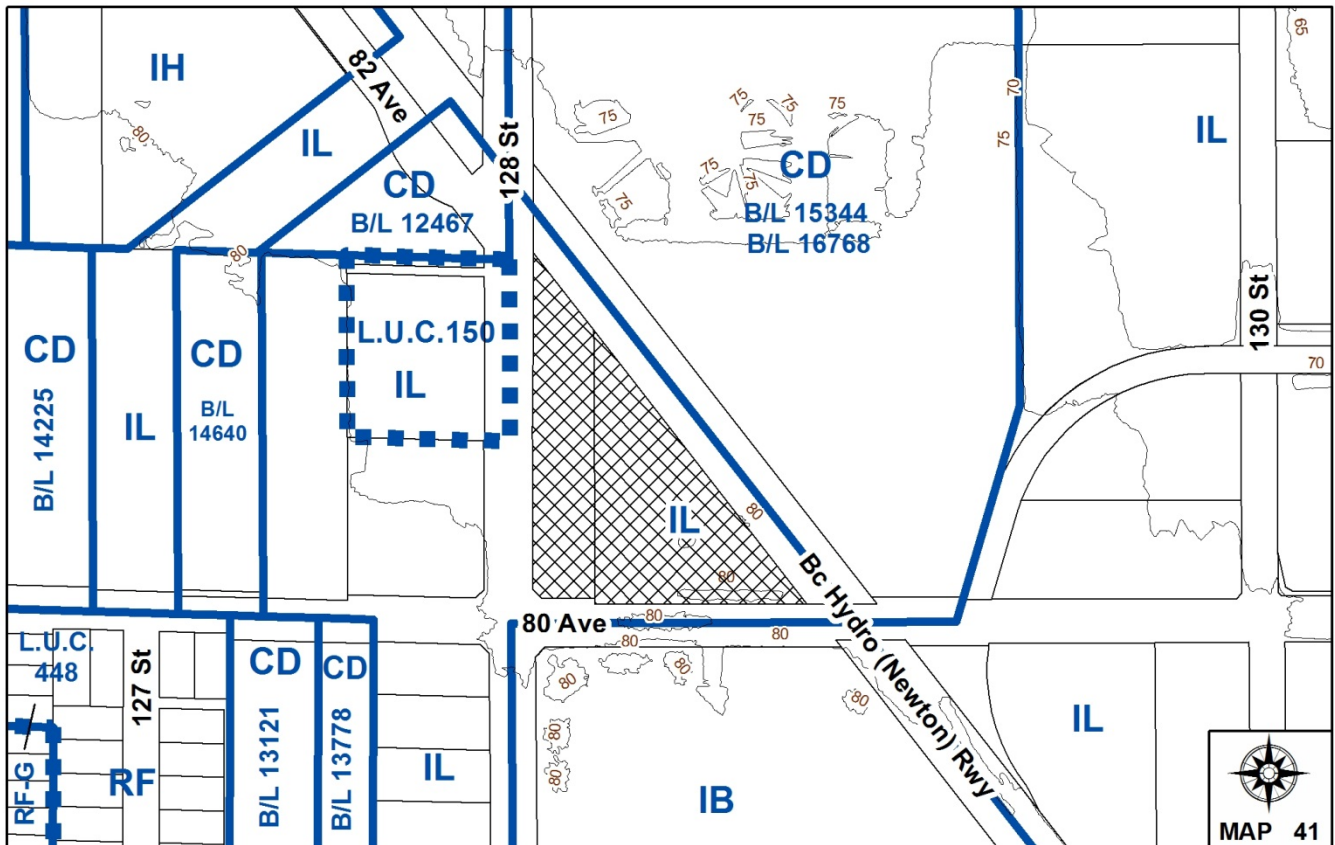

RECOMMENDATION SUMMARY

- By-law Introduction and set date for Public Hearing for:
 - OCP Amendment; and
 - Rezoning.
- Approval to draft Development Permit.
- Pass a resolution to adopt the Central Newton Cultural Commercial District Guidelines, including the funding formula for off-site boulevard improvements.
- Pass a resolution to refer the application to Metro Vancouver to amend Metro Vancouver's Regional Growth Strategy Land Use designation from "Industrial" to "Mixed Employment" for the subject site.

DEVIATION FROM PLANS, POLICIES OR REGULATIONS

- The applicant is proposing an OCP Amendment from "Industrial" to "Commercial" and to amend the Newton Local Area Plan (LAP) from "High Impact Industrial" to "Commercial".

RATIONALE OF RECOMMENDATION

- The proposed development is in accordance with the proposal to develop a cultural commercial node located at the intersection of 80 Avenue and 128 Street, as outlined in the July 9, 2012 Corporate Report (No. R157) regarding the establishment of the Central Newton Cultural Commercial District (CNCCD).
- The proposal complies with the design guidelines for the CNCCD. The proposal enhances the aesthetics of the area, creates a sense of place and improves the pedestrian experience of the area.
- The development of a unique commercial district in the central Newton area adds to the diversity of retail experience in the City and acts as a retail draw for surrounding areas with economic benefits to the City.

RECOMMENDATION

The Planning & Development Department recommends that:

1. a By-law be introduced to amend the OCP by redesignating the subject site in Development Application No. 7913-0047-00 from "Industrial" to "Commercial" and a date for Public Hearing be set.
2. Council determine the opportunities for consultation with persons, organizations and authorities that are considered to be affected by the proposed amendment to the Official Community Plan, as described in the Report, to be appropriate to meet the requirement of Section 879 of the Local Government Act.
3. a By-law be introduced to rezone the subject site in Development Application No. 7913-0047-00 from "Light Impact Industrial Zone (IL)" (By-law No. 12000) to "Comprehensive Development Zone (CD)" (By-law No. 12000) and a date be set for Public Hearing.
4. Council authorize staff to draft Development Permit No. 7913-0047-00, including a comprehensive sign design package, generally in accordance with the attached drawings (Appendix II).
5. Council instruct staff to resolve the following issues prior to final adoption:
 - (a) ensure that all engineering requirements and issues including restrictive covenants, dedications, and rights-of-way where necessary, are addressed to the satisfaction of the General Manager, Engineering;
 - (b) submission of a subdivision layout to the satisfaction of the Approving Officer;
 - (c) submission of a finalized tree survey and a statement regarding tree preservation to the satisfaction of the City Landscape Architect;
 - (d) submission of a landscaping plan and landscaping cost estimate to the specifications and satisfaction of the Planning and Development Department;
 - (e) demolition of existing buildings and structures to the satisfaction of the Planning and Development Department;
 - (f) registration of a Section 219 Restrictive Covenant to adequately address the City's needs with respect to public art, to the satisfaction of the General Manager Parks, Recreation and Culture;
 - (g) discharge of the Section 219 Restrictive Covenant (PB009690) limiting use on the site to "a metal machining fabrication plant and office";
 - (h) discharge of the Section 219 Restrictive Covenant (BP009686) restricting access to 80 Avenue from the existing driveway on the parcel at 8020 - 128 Street;

- (i) execution of the "Corridor License Agreement" with BC Hydro to allow for the lease of a portion of the adjacent BC Hydro railway right-of-way for parking and landscaping purposes;
 - (j) resolution of outstanding urban design issues; and
 - (k) acceptance by Metro Vancouver of the proposed amendment of Metro Vancouver's Regional Growth Strategy Land Use Classification from "Industrial" to "Mixed Employment" for the subject site.
6. Council pass a resolution to adopt the Central Newton Cultural Commercial District Guidelines, including the funding formula for off-site boulevard improvements as outlined in the Guidelines.
7. Council pass a resolution to authorize referral of the application to Metro Vancouver to amend Metro Vancouver's Regional Growth Strategy Land Use Classification from "Industrial" to "Mixed Employment" for the subject site.
8. Council pass a resolution to amend the Newton LAP to redesignate the subject site from "High Impact Industrial" to "Commercial" when the project is considered for final adoption.

REFERRALS

Engineering:	The Engineering Department has no objection to the project subject to the completion of Engineering servicing requirements as outlined in Appendix III.
Ministry of Environment (MOE):	MOE has no objections to the proposal. The applicant was issued a Certificate of Compliance on May 12, 2011 for the site. The Certificate of Compliance is valid for the proposed development.
Surrey Fire Department:	No concerns.
B.C. Hydro:	BC Hydro has no objections to the proposed development. The applicant is leasing a portion of the BC Hydro lands adjacent to the site for parking and landscaping purposes.

SITE CHARACTERISTICS

Existing Land Use: Industrial business.

Adjacent Area:

Direction	Existing Use	OCP/LAP Designation	Existing Zone
North and East (Across BC Hydro rail line):	Industrial/commercial site, under application no. 7911-0313-00 for rezoning/OCP amendment to full commercial uses.	Industrial/ High Impact Industrial	CD By-law Nos. 15344 & 16768
South (Across 80 Avenue):	Industrial/commercial site.	Industrial/ High Impact Industrial	IB
West (Across 128 Street):	Industrial sites, under application no. 7906-0121-00 for rezoning/OCP amendment to full commercial uses.	Industrial/ General Industrial	IL and L.U.C. No. 150

JUSTIFICATION FOR PLAN AMENDMENTOCP and Newton LAP Amendment

- The applicant is proposing to amend the OCP from "Industrial" to "Commercial" and the Newton LAP from "High Impact Industrial" to "Commercial".
- The proposed OCP and LAP amendments are in accordance with the proposal to develop a cultural commercial node located at the intersection of 80 Avenue and 128 Street, as outlined in the July 9, 2012 Corporate Report (No. R157) regarding the establishment of the Central Newton Cultural Commercial District (CNCCD) (Appendix VI).

Metro Vancouver Regional Growth Strategy Amendment

- The subject site is designated "Industrial" in Metro Vancouver's Regional Growth Strategy (RGS). To accommodate the proposed OCP Amendment and rezoning, the subject site needs to be redesignated from "Industrial" to "Mixed Employment" in Metro Vancouver's RGS (Appendix X).
- The proposed amendment is a Type 3 minor amendment to the Metro Vancouver RGS. If authorized by Council, staff will refer the application to Metro Vancouver after Third Reading where it will be reviewed and voted on by the Metro Vancouver Board. There is no public hearing and the application needs a simple majority (50% plus 1) to be approved.
- Two other properties, within the proposed CNCCD, the Payal and York Business Centres, are already designated "Mixed Employment" in the RGS.

DEVELOPMENT CONSIDERATIONS

Background

- The subject site consists of 2 parcels located at 8020 – 128 Street and 12829 - 80 Avenue. The parcels are zoned IL. The subject site is 1.48 hectares (3.66 acres) in size.
- The subject site is bordered on all 4 sides by a mixture of commercial and industrial uses, all of which are in the proposed CNCCD. The sites to the north, east and west are currently under similar applications (OCP amendment to "Commercial" and rezoning to full commercial uses), but are pre-Council.
- The subject site contains a number of existing buildings and structures, which will be required to be demolished as a condition of rezoning approval.

Proposal

- The applicant is proposing:
 - an OCP amendment from "Industrial" to "Commercial";
 - a rezoning from IL to CD (based on C-8);
 - a development permit to allow 5 commercial buildings with a total floor area of 9,206 sq.m. (99,090 sq.ft.); and
 - a lot consolidation of the 2 parcels.

Central Newton Cultural Commercial District Guidelines and Boulevard Improvement Funding Formula

- On July 9, 2012, Council authorized staff to proceed with establishing the CNCCD (Corporate Report No. R157, attached as Appendix V). Staff have conducted several meetings with area stakeholders and have developed guidelines for the proposed commercial district (Appendix VI).
- The CNCCD guidelines define the study area, provide guidance on site design and character, and outline improvement requirements for the off-site street boulevard area as well as a funding formula for this work.
- The proposed off-site boulevard improvements include relocation of sidewalk, new strip of planting and street trees, and new pedestrian lighting (Appendix VI). The estimated value of off-site boulevard improvements along 128 Street and 80 Avenue is approximately \$1.2M .
- It is proposed that the developed sites (Payal Business Centre and York Business Centre) will be responsible for the off-site boulevard improvements in the CNCCD. The rationale for this arrangement is that the two developed sites had substantial cost savings on Development Cost Charges when the buildings were constructed under industrial rates.

- The proposed funding formula is for Payal Business Centre and York Business Centre to share the approximately \$1.2M off-site boulevard improvement cost on a per acre basis. Payal Business Centre is 18.4 acres in area and York Business Centre is 9.0 acres. Therefore Payal Business Centre would be responsible for contributing 67% of the cost and York Business Centre is responsible for the remaining 33% of the cost.

Proposed CD Zone

- The applicant is proposing a CD Zone based on the "Community Commercial Zone (C-8)". The following is a table outlining the differences between the C-8 Zone and the proposed CD Zone:

	C-8 Zone	Proposed CD Zone
Permitted Uses	Retail stores are permitted. Eating establishments are permitted.	Retail stores are permitted, but are limited to a maximum individual floor area of 370 sq.m. (4,000 sq.ft.). Eating establishments are permitted, but are limited to a maximum individual floor area of 150 sq.m. (1,600 sq.ft.).
Building Height	12.0 metres (40 ft.)	14.0 metres (46 ft.)
Minimum Setbacks	All setbacks – 7.5 metres (25 ft.)	South yard – 3.0 metres (10 ft.) West yard – 3.4 metres (11 ft.) East yard – 0.0 metres

- The proposed CD zone limits the size of retail stores and eating establishments to ensure the proposal meets the parking requirements.
- The applicant is proposing a building height of 12.5 metres (41 feet). The proposed CD By-law allows for a building height of 14.0 metres (46 feet) to allow for any grading or height issues that may arise during construction. The site is surrounded on all sides by road or railway so the potential increase in building height will not impact any neighbouring properties.
- The proposed setback reductions reflect the goal of bringing the buildings closer to the street to enhance the streetscape in the CNCCD. In addition, the triangular geometry of the site is more challenging for building siting and parking layout, and the proposed reductions allow for a more efficient use of this triangular site.

Watercourses

- There are 2 Class C watercourses in the BC Hydro railway property adjacent to the subject site. The applicant's registered professional biologist visited the site and confirmed these watercourses as Class C watercourses. No setbacks are required for Class C watercourses and therefore these watercourses do not impact the proposed redevelopment of the subject site.

DESIGN PROPOSAL AND REVIEW

Access, Pedestrian Circulation and Parking

- The applicant is proposing 2 vehicular accesses to the site. The access on 128 Street will be a right-in/right-out and left-in access. The access on 80 Avenue will be right-in/right-out only.
- The existing Section 219 Restrictive Covenant (BP009686) restricting access to 80 Avenue from the existing driveway on the parcel at 8020 – 128 Street can be discharged as the parcels are being consolidated and that driveway is proposed to be removed.
- The applicant is proposing pedestrian connections between the proposed street-oriented buildings and the sidewalks along 80 Avenue and 128 Street, and also between the various buildings on the site.
- A total of 220 parking spaces are required for the proposed development. The applicant is proposing to provide 222 parking spaces. The applicant is proposing to limit the maximum floor area of retail units to 370 sq.m. (4,000 sq.ft.) and eating establishments to 150 sq.m. (1,600 sq.ft.) to aid the proposal in meeting the parking requirements.

Site and Building Design

- The applicant is proposing 2 two-storey buildings with office on the second floor and retail on the ground floor. The other 3 proposed buildings are one-storey retail buildings. The total floor area proposed is 9,206 sq.m. (99,090 sq.ft.).
- The site design reflects an effort to place more buildings along the street frontage (as opposed to the interior of the site), reducing the amount of parking visible from the street and providing an attractive interface with the public realm.
- The large corner building (Building 2) will have 2 internal breeze-ways that connect the front of the buildings to the parking area in the interior of the site. Building 2 is also proposed to have a very large glazed area at the corner, which will strongly enhance the streetscape at the intersection of 80 Avenue and 128 Street, in accordance with the CNCCD design guidelines.
- The 5 buildings are proposed to be tilt-up concrete buildings. The proposed finishing materials include significant amounts of glazing, cedar plank siding, stone veneer, and glass spandrel panels. Metal window canopies, steel and glass weather canopies, articulation, vertical differentiation between the individual units, and large dramatic roof canopies enhance the building design.
- The applicant is proposing a lively colour scheme in keeping with the CNCCD design guidelines, which will help to provide this area with a unique identity. Proposed exterior colours include light blue, yellow, pink and orange.

Signage

- The applicant is proposing to locate 1 free-standing signs on the property, along 128 Street. The sign is proposed to be 6.1 metres (20 feet) in height. The sign is proposed to contain stone veneer, stained cedar block, a tenant signage area and a decorative steel I-beam. The materials proposed complement the materials proposed for the buildings.
- The applicant is proposing illuminated channel letter fascia signs for the buildings. The fascia signage is proposed to be 0.6 metres (2 feet) in height. High quality logo or channel letter signage is permitted on the second floor as per the CNCCD design guidelines.

Landscaping and Lighting

- The applicant is proposing hard and soft landscaping elements along the 128 Street and 80 Avenue streetscape. Deciduous trees, landscape beds, decorative lighting, benches, and special paving will provide an attractive interface with the public realm.
- The main drive aisle through the site is proposed to incorporate coloured, patterned paving, in accordance with the CNCCD design guidelines. A gabion wall landscape feature is proposed for the north end of the site. The applicant is also proposing various trees and shrub planting throughout the site.
- Two garbage enclosures are proposed in the parking area. The materials used will be in keeping with the character of the proposed buildings.
- The applicant is proposing Lumec Urbanscape light fixtures along the street frontages, within the site. These lights contain LED lights that can be switched to multiple colors. These pedestrian scale lights will animate the streetscape and will help provide the area with a unique character. It is proposed that the same lights will be used on the other sites within the CNCCD along 80 Avenue and 128 Street.

TREES

- An arborist report was prepared for the site. The arborist report states that there are a total of 12 trees on the site. The applicant is proposing to remove all of the trees because they're poor quality species or conflict with proposed construction.
- The following is a table providing the breakdown by tree species:

Tree Species	Total no. of mature trees (on-site)	Total proposed for retention (on-site)	Total proposed for removal (on-site)
Alder	5	0	5
Birch	3	0	3
Cottonwood	2	0	2
Western Hemlock	1	0	1
Douglas Fir	1	0	1
Total	12	0	12

- The applicant is required to plant 17 replacement trees and the applicant is proposing to plant 137 replacement trees.

ADVISORY DESIGN PANEL

This application was referred to the Advisory Design Panel (ADP) on September 26, 2013 (Appendix VII). The ADP comments and suggestions have either been satisfactorily addressed or will be addressed before final adoption.

PRE-NOTIFICATION

Pre-notification letters were sent on September 18, 2013 and staff received 2 letters. The letter writers do not support the proposed rezoning from industrial to commercial uses and express concerns that there is already enough commercial development in the area within the York and Payal Business Centres.

SUSTAINABLE DEVELOPMENT CHECKLIST

The applicant prepared and submitted a sustainable development checklist for the subject site on November 19, 2013. The table below summarizes the applicable development features of the proposal based on the seven (7) criteria listed in the Surrey Sustainable Development Checklist.

Sustainability Criteria	Sustainable Development Features Summary
1. Site Context & Location (A1-A2)	<ul style="list-style-type: none"> • The subject site is in an urban infill area. • The development is consistent with the proposed CNCCD guidelines.
2. Density & Diversity (B1-B7)	<ul style="list-style-type: none"> • n/a
3. Ecology & Stewardship (C1-C4)	<ul style="list-style-type: none"> • The applicant is proposing to utilize dry swales, absorbent soils greater than 30 cm (1 foot) in depth, roof downspout disconnection, and on-site infiltration trenches or sub-surface chambers.
4. Sustainable Transport & Mobility (D1-D2)	<ul style="list-style-type: none"> • There are pedestrian walkways on site and many connections with City sidewalks. Pedestrian-specific lighting and covered outdoor waiting areas will be provided. Bike racks will also be provided.
5. Accessibility & Safety (E1-E3)	<ul style="list-style-type: none"> • CPTED principles are incorporated in the landscaping design. All the units are accessible.
6. Green Certification (F1)	<ul style="list-style-type: none"> • n/a
7. Education & Awareness (G1-G4)	<ul style="list-style-type: none"> • The typical pre-notification and development proposal signage process was followed.

INFORMATION ATTACHED TO THIS REPORT

The following information is attached to this Report:

Appendix I.	Lot Owners, Action Summary and Project Data Sheets
Appendix II.	Proposed Sign By-law Variances Tables
Appendix III.	Site Plan, Building Elevations, Landscape Plans and Renderings
Appendix IV.	Engineering Summary
Appendix V.	July 9, 2012 Corporate Report No. R157 "Establishment of a Central Newton Cultural Commercial District"
Appendix VI.	Central Newton Cultural Commercial District Guidelines
Appendix VII.	ADP Comments and Applicant's Response
Appendix VIII.	OCP Redesignation Map
Appendix IX.	Proposed CD By-law
Appendix X.	Metro Vancouver Regional Land Use Designation Map

original signed by Nicholas Lai

Jean Lamontagne
General Manager
Planning and Development

KB/da

\\file-server1\net-data\csdc\generate\areaproduct\save\26991392056.doc
DRV 11/21/13 11:39 AM

Information for City Clerk

Legal Description and Owners of all lots that form part of the application:

1. (a) Agent: Name: Oleg Verbenkov
 Pacific Land Resource Group Inc.
 Address: #101, 7485 - 130 Street
 Surrey, BC V3W 1H8

 Tel: 604-501-1624

2. Properties involved in the Application
 - (a) Civic Address: 12829 - 80 Avenue
 8020 - 128 Street

 - (b) Civic Address: 12829 - 80 Avenue
 Owner: Muric Enterprises Ltd.
 PID: 000-665-151
 Parcel "C" (692019E) Lot 2 Except: Parcel "B" (Reference Plan 13512), South West Quarter
 Section 29 Township 2 New Westminster District Plan 3270

 - (c) Civic Address: 8020 - 128 Street
 Owner: Muric Enterprises Ltd.
 PID: 001-547-887
 Parcel "B" (Reference Plan 13512) Of Lot 2 Except: Part Dedicated Road On Plan LMP42363
 South West Quarter Section 29 Township 2 New Westminster District Plan 3270

3. Summary of Actions for City Clerk's Office
 - (a) Introduce a By-law to amend the Official Community Plan to redesignate the property
 from "Industrial" to "Commercial".

 - (b) Introduce a By-law to rezone the property.

DEVELOPMENT DATA SHEET

Proposed Zoning: CD (based on C-8)

Required Development Data	Minimum Required / Maximum Allowed	Proposed
LOT AREA* (in square metres)		
Gross Total		14,848 sq.m.
Road Widening area		1,097 sq.m.
Undevelopable area		
Net Total		13,751 sq.m.
LOT COVERAGE (in % of net lot area)		
Buildings & Structures	50%	34%
Paved & Hard Surfaced Areas		
Total Site Coverage		
SETBACKS (in metres)		
South Yard	3m	3m
West Yard	3.4m	3.4m
East Yard	0m	0m
BUILDING HEIGHT (in metres/storeys)		
Principal	14m	12.5m
Accessory		
NUMBER OF RESIDENTIAL UNITS		
Bachelor		
One Bed		
Two Bedroom		
Three Bedroom +		
Total		
FLOOR AREA: Residential		
FLOOR AREA: Commercial		
Retail		4,991 sq.m.
Office		4,510 sq.m.
Total		
FLOOR AREA: Industrial		
FLOOR AREA: Institutional		
TOTAL BUILDING FLOOR AREA		9,501 sq.m.

** If the development site consists of more than one lot, lot dimensions pertain to the entire site.*

Development Data Sheet cont'd

Required Development Data	Minimum Required / Maximum Allowed	Proposed
DENSITY		
# of units/ha /# units/acre (gross)		
# of units/ha /# units/acre (net)		
FAR (gross)		
FAR (net)	0.80	0.69
AMENITY SPACE (area in square metres)		
Indoor		
Outdoor		
PARKING (number of stalls)		
Commercial	220	222
Industrial		
Residential Bachelor + 1 Bedroom		
2-Bed		
3-Bed		
Residential Visitors		
Institutional		
Total Number of Parking Spaces	220	222
Number of disabled stalls	2	4
Number of small cars		
Tandem Parking Spaces: Number / % of Total Number of Units		
Size of Tandem Parking Spaces width/length		

Heritage Site	NO	Tree Survey/Assessment Provided	YES
---------------	----	---------------------------------	-----

Appendix II

PROPOSED SIGN BY-LAW VARIANCES

#	Proposed Variances	Sign By-law Requirement	Rationale
1	To allow for fascia signs on the second floor of the buildings.	A maximum of 1 fascia sign per lot frontage on the second floor for the largest second floor tenant.	The CNCCD allows additional signage on the second floor.
2	To allow more than 2 fascia signs per premises.	A maximum of 2 fascia signs are permitted for each premises.	Some premises have 3 elevations and thus can have more than 2 signs. Some premises may have a long facade and thus may desire more than 1 sign along that façade.

PROPOSED COMMERCIAL DEVELOPMENT

8020-128 STREET, 12829- 80 AVENUE & 12865 - 80 AVENUE, SURREY, BRITISH COLUMBIA

NOTES:

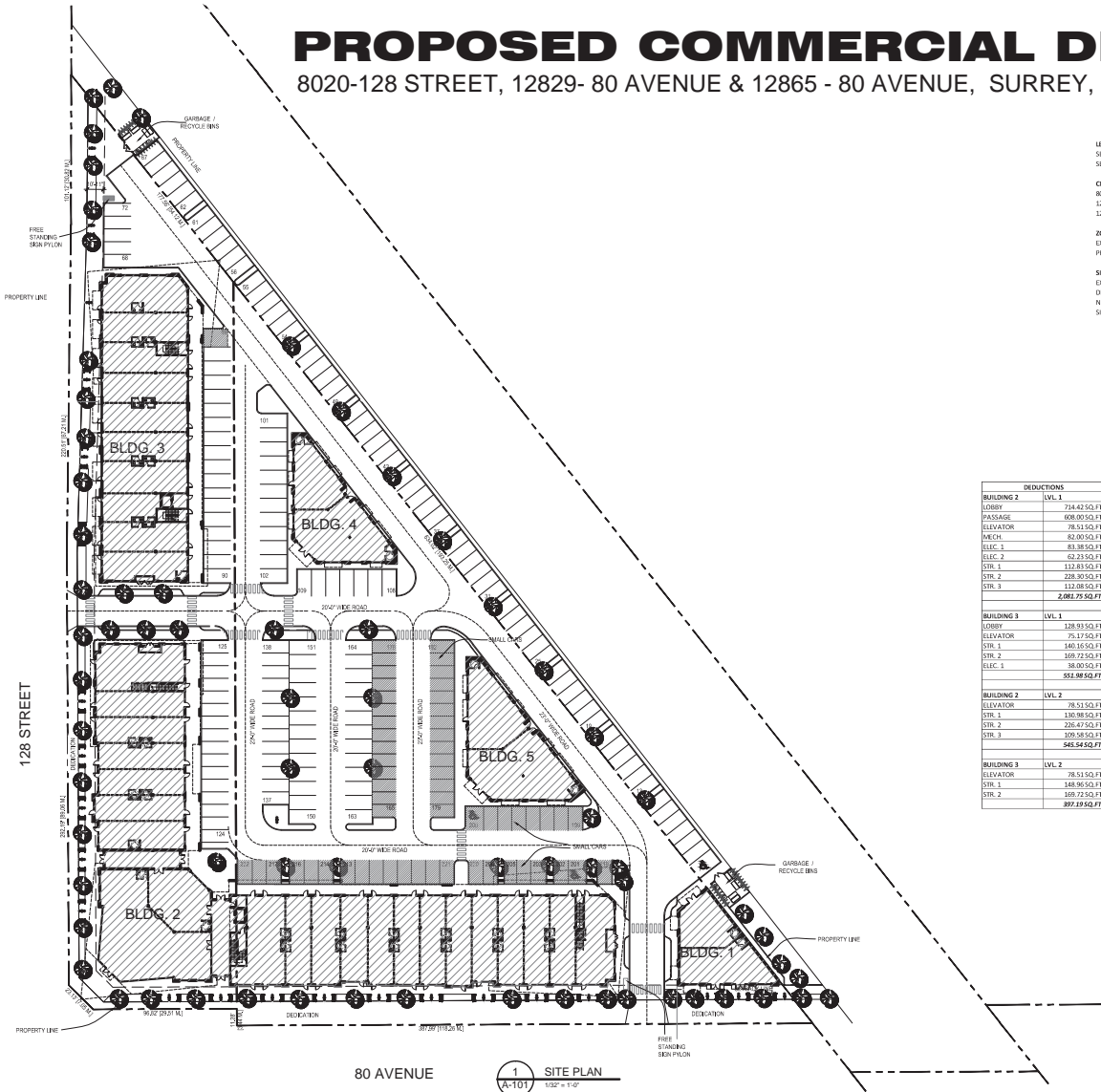

DEVELOPMENT DATA

LEGAL ADDRESS		DEVELOPMENT DATA	
SEC 20 TWP 2 NWD SEC 20 TWP 2 N, 21, 22 W 10		IL	
CIVIC ADDRESS		CD	
8020- 128 STREET, SURREY, B.C. 12829 - 80 AVENUE, SURREY, B.C. 12865 - 80 AVENUE, SURREY, B.C.			
ZONING SYNOPSIS			
EXISTING ZONE			
PROPOSED ZONE			
SITE			
EXISTING	159,824 SQ. FT.	14,848 SQ. MT.	3.67 ACRE / 1.49 HECTARE
DEDICATIONS	31,803 SQ. FT.		
NET SITE AREA	148,021 SQ. FT.	13,752 SQ. MT.	3.40 ACRE / 1.38 HECTARE
SITE COVERAGE	53,798 SQ. FT.		
			33.62%

FAR CALCULATIONS

BUILDING	RETAIL	
BUILDING 1	2,805.58 SQ. FT.	
BUILDING 2	30,933.00 SQ. FT.	
BUILDING 3	-2,081.75 SQ. FT.	
BUILDING 4	12,064.00 SQ. FT.	
BUILDING 4	951.98 SQ. FT.	
BUILDING 4	3,581.69 SQ. FT.	
BUILDING 5	4,157.30 SQ. FT.	
TOTAL	51,091.88 SQ. FT.	
PARKING	180.71 CARS	2.75 CARS PER 1,075 SQ. FT.

BUILDING	OFFICE	
BUILDING 2	34,474.55 SQ. FT.	
BUILDING 3	-545.54 SQ. FT.	
BUILDING 3	14,067.00 SQ. FT.	
BUILDING 3	-187.19 SQ. FT.	
TOTAL	47,996.87 SQ. FT.	
PARKING	89.30 CARS	2.00 CARS PER 1,075 SQ. FT.

TOTAL FSR AREA	99,090.21 SQ. FT.
PARKING CALCULATIONS	
RETAIL	180.71 CARS
OFFICE	89.30 CARS
TOTAL PARKING REQUIRED	220 CARS
TOTAL PARKING PROVIDED	222 CARS
SMALL CARS	58 CARS
STANDARD STALLS	164 CARS
	(26.13% OF TOTAL PARKING)
ACCESSIBLE PARKING	
REQUIRED	2 CARS
PROVIDED	4 CARS
	1 FOR EVERY 100 STALLS

BUILDING	LEVEL	DEDUCTIONS	
BUILDING 2	LVL. 1	LOBBY	714.42 SQ. FT.
		PASSAGE	698.00 SQ. FT.
		ELEVATOR	78.53 SQ. FT.
		MECH.	82.00 SQ. FT.
		ELEC. 1	83.38 SQ. FT.
BUILDING 3	LVL. 1	ELEC. 2	82.23 SQ. FT.
		STR. 1	112.83 SQ. FT.
		STR. 2	228.30 SQ. FT.
		STR. 3	112.08 SQ. FT.
BUILDING 2	LVL. 2	ELEC. 1	553.98 SQ. FT.
		ELEVATOR	78.53 SQ. FT.
		STR. 1	130.58 SQ. FT.
		STR. 2	236.47 SQ. FT.
		STR. 3	109.58 SQ. FT.
BUILDING 3	LVL. 2	ELEVATOR	78.53 SQ. FT.
		STR. 1	148.96 SQ. FT.
		STR. 2	189.72 SQ. FT.
		STR. 3	397.85 SQ. FT.

1	
2	
3	
4	
5	
6	
7	
8	
9	
10	
11	
12	
13	
14	
15	
16	
17	
18	
19	
20	
21	
22	
23	
24	
25	
26	
27	
28	
29	
30	
31	
32	
33	
34	
35	
36	
37	
38	
39	
40	
41	
42	
43	
44	
45	
46	
47	
48	
49	
50	
51	
52	
53	
54	
55	
56	
57	
58	
59	
60	
61	
62	
63	
64	
65	
66	
67	
68	
69	
70	
71	
72	
73	
74	
75	
76	
77	
78	
79	
80	
81	
82	
83	
84	
85	
86	
87	
88	
89	
90	
91	
92	
93	
94	
95	
96	
97	
98	
99	
100	



1205-4871 SHELL ROAD
RICHMOND, BRITISH COLUMBIA
CANADA, V6V 3Z6
T: (604) 278-5118 F: (604) 278-5111
info@dfarchitecture.ca

PROJECT: PROPOSED COMMERCIAL DEVELOPMENT
8020-128 STREET, 12829-80 AVENUE & 12865-80 AVENUE, SURREY, B.C.

CLIENT: 0712680 BC LTD.

DESIGNED BY: ADVISORY DESIGN PANEL
ADP MEETING: 28th SEPT., 2013
7913-0047-00

DATE:	2013
REVISION:	A
SCALE:	1/2" = 1'-0"
DWG NO.:	04-009
SHEET:	02 AUG. 2013
SHEET TITLE:	

SITE PLAN & DEVELOPMENT DATA

DWGING NO.:	A-101	C
-------------	-------	---

80 AVENUE 1 SITE PLAN 1/32" = 1'-0"

GOAL: TO CREATE AN INVITING COMMERCIAL CENTRE WITH CULTURAL AMENITIES AND A UNIQUE CHARACTER



Visually scaling the down the length of the buildings with vertical articulation by stepping down the roof forms and articulating the facade



To use individually illuminated channel type letters including internally illuminated or back-lighted solid letters which are supported and not exceeding 18" in height



Allow second floor fascia signage
Allow projection signs
Do not allow signage to fully cover windows
Do not allow banners as permanent business signage
Encourage lighted signs



Locating higher building forms along street and corners.



Designing ancillary or secondary buildings to the same architectural level of form and character as the principal buildings.



Locating the buildings along the street to create a retail walking environments along the public streets.

USING CONTEMPORARY ARCHITECTURE

Character should be simple, contemporary high quality building, with colour and decoration added

Increase the use of colour and new materials to enhance vibrancy

Building should engage streets/drive aisles with active facades, and be brought closer to the street



Featured decorative pavers on selected areas

Use architectural features (i.e. canopies, glazing) to celebrate different uses

Add specialty character features on columns

Improve pedestrian amenity with upgraded weather protection



Providing continuous, architecturally integrated weather protection over public interfaces including sidewalks, public open spaces, along building frontages and at building entrances. Materials such as glass and metals are to be considered.



FORM & CHARACTER DEVELOPMENT

NOTES:

2013/1/21	C
2013/2/20	B
2013/3/21	A



1205-4871 SHELL ROAD
RICHMOND, BRITISH COLUMBIA
CANADA V6V 3Z8
T: (604) 284-5194 F: (604) 284-5131
info@dfarchitecture.ca

PROJECT:
PROPOSED COMMERCIAL DEVELOPMENT
8020-128 STREET, 12820-80 AVENUE & 12865-80 AVENUE, SURREY, B.C.

CLIENT:

0712680 BC LTD.

SUBMISSION TO
ADVISORY DESIGN PANEL
ADP MEETING: 26th SEPT., 2013
7813-0047-00

COPYRIGHT RESERVED. THIS PLAN AND DESIGN ARE AT ALL TIMES THE PROPERTY OF DESIGNER. NO PART OF ANY INTELLECTUAL PROPERTY OR DESIGN IS TO BE REPRODUCED OR TRANSMITTED IN ANY FORM OR BY ANY MEANS WITHOUT THE WRITTEN PERMISSION OF THE DESIGNER.	
DATE:	
VERSION:	
SCALE:	1/4" = 1'-0"
DWG No.:	049 009
DATE:	30 AUG. 2013
SHEET TITLE:	

PRECEDENT PHOTOS

DWING NO.:	A-003	C
------------	-------	---

PROJECT DESCRIPTION

The proposed commercial development at 8020-128 Ave. 12829 & 12855 - 80 Avenue, Surrey BC is a combined development for retail and offices located in various buildings within the site having a site area of 159,429 sq.ft. All commercial retail units are housed in either one-storey building or in a 2-storey building in which case, the upper level are office units. The total built-up area is 96,600 sq.ft. approx.

The whole development lies on the northeast corner of 128 Street and 80th Avenue in Surrey. The three individual parcels of lots form a triangular lot adjoining with the BC Hydro Right of Way on the northeast side of the property.

PLANNING OBJECTIVE

The site is within the Central Newton Cultural District. It is planned to achieve the objective as stated in the document entitled "Central Newton Cultural District Design Guidelines" dated May 2013.

DESIGN REVIEW

Context

The site is bounded to the west by 128 Street, to the south by 80th Avenue, to the northeast by BC Hydro ROW. The site has an existing light industrial building in closed proximity with 128 Street. The site is currently zoned as Light Impact Industrial Zone (LI) hence the existing buildings in the close vicinity are of light industrial type structures.

Site Development

The site is relatively flat. The site is fed with 2 main entry/exit driveways at 128 Street and 80th Avenue from which it serve vehicular circulation to retail units located in the site. The L-shaped 2-storey main building (Building No. 2) housing retail units on level 1 and offices on level 2, are located facing the 128 Street and 80th Avenue. A smaller 2-storey building (Building No. 3) with the same character as the main building is located adjacent to the north Building No. 2. This is separated by an entry/exit driveway. The bulk of parking is centrally located at the area behind Building No. 2. Other parking areas are in between Buildings 3 and 4, Building No. 4 located on the north tip of the site is served with parking and designed with an 18 car capacity queuing line in the drive-through. Parking area is also located along the length of the property line facing the BC Hydro Right of Way. The site is served with a 20 feet wide and 23 feet wide driveways. Other smaller buildings in the site are connected to the main building and to other units by a series of pedestrian footpaths.

Along the 128 Street and 80th Avenues, a continuous sidewalk is provided along the length of the property dotted with deciduous trees in grass beds bordered with low hedges along the walkways; these are intermittently broken with areas having benches and ornamental street lighting.

This Design Rationale is in keeping with the Central Newton Cultural District Design Guidelines. As such, the design objectives which were drawn from the guidelines for this area were considered to effectively arrive and develop the architectural form and character of this commercial development.

Objectives:

- Establish this area as a street oriented and pedestrian friendly commercial development.
- Implement a street oriented commercial theme for this area.
- Preserve and enhance elements of the natural environment in juxtaposition to development.

Design Direction:

- Create a safe and accessible public realm that incorporates CPTD principles.
- Ensure a gradual transition and so that retaining walls are avoided.
- Locate parking away from street frontages at street corners.
- Locate wheelchair accessible parking spaces close to building entrances
- The shape and exterior finishes of buildings should be sufficiently varied to avoid a monotonous appearance when the development is viewed in the whole. Natural materials (e.g. wood siding, stones and windows are encouraged).
- The shape, slope and finish of the roofs should be such that when viewed from above they appear clean and attractive and can maintain the quality over time.
- The development should have a sense of unity, but should not be made monotonous through repetition of building form.
- Exterior lighting and signs should be unobtrusive in scale with their surroundings and be used to unify the development.
- Technical approach to noise abatement shall be employed in building construction in the area.
- All parking should behind buildings and well concealed from public view on 128th Street and 80th Avenue.
- The site shall be well landscaped.
- Streetscaping/ trees shall be provided on specified boulevards.

The materials palette will be consistent throughout the development. Glass canopies protecting the window openings on lower levels and metal canopies protecting window openings on upper levels are typical features to the main building including building no. 3. Decorative "roof fly beam" as features to end corners of buildings number 2 and 3 dramatically framed the two buildings as one cohesive building element. Warm and bright color schemes were coordinated to compliment the lively and active character and add interest in the development.

Material Palette

- Roofing** - Flat roof with sloped insulation protected with 2 ply waterproofing membrane.
- Exterior wall** - Cedar plank siding, 6" exposure (or metal siding to mimic cedar finish)
Stone veneer treatment on featured pilasters.
Finished concrete as formed with tilt-up wall.
- Canopy** - Glass canopy on steel channel frames supported with tie rod and turnbuckle.
- Exterior soffit** - Painted cedar slat with gap in between

Exterior window glazing
Aluminum framed double glazing

- Curtain wall glazing** - High efficiency double glazed curtain wall glazing panels with intermittent patch of colored glazing.
Glass spandrel panels to conceal the 2nd floor and roof structures but consistent with the texture and color scheme of the general glazing system.



LANDSCAPE DESIGN RATIONALE

Streetscape:

The proposed site layout provides for a street oriented and pedestrian friendly commercial development as envisioned in the approved objectives and guidelines of the Central Newton Cultural Commercial District OCP.

The well-landscaped treatment fronting 80th Avenue and 128th Street is designed to fit in with the proposed streetscape as per the norms set by the revised OCP. This organized streetscape includes deciduous street trees, lawn boulevards, street lamps, and a separated concrete sidewalk. Retail units have windows overlooking the street and private doors with access to the street.

The adjacent ROW of BC Hydro property north-east of the project is screened with low hedges and columnar trees - integrating with the proposed streetscape along 128th Street.

Front Entry Features

The entry driveway incorporates colored, patterned paving for pedestrian access, and is framed by pyramidal european hornbeam corridor and planted with an assortment of low, flowering shrubs. A project sign with stone base, pieglass signage for tenants surmounted by a stained wooden block and metal sign will identify the complex name and address.

Internal Streets and Entries

The main internal street meanders to slow traffic and incorporates colored, patterned paving for pedestrian circulation along one side and at intersection areas. Flowering trees and shrub bed plantings are incorporated into the main roadway edges to provide a well-landscaped site as per landscape guidelines requirements.

Internal roadways are envisioned as safe, quiet, semi-public spaces. Open sight-lines on the roadways, site lighting, and "eyes on the street" from the adjacent homes, will provide a safe setting for casual, paved play activities and general everyday use.

Pedestrian walkways are paved with colored, unit pavers with small feature planting beds adding pedestrian scale and interest.

Perimeter Fencing

Crime Prevention Through Environmental Design (CPTED):
CPTED principles are incorporated into in the landscape design including:

- Shrub planting heights kept down below eye level
- Lower branches of trees kept up above eye level
- Site lighting and open sight-lines for pedestrian pathways
- Open sight-lines into the main commercial outlets
- Open sight-lines and lighting between parking and the lobby entrances for office areas
- All parking and pedestrian areas are well lit with street lighting and wall lights provided along all building faces
- Character of internal roadways employs "eyes on the street" with windows, doorways and entries providing safe oversight to public areas.

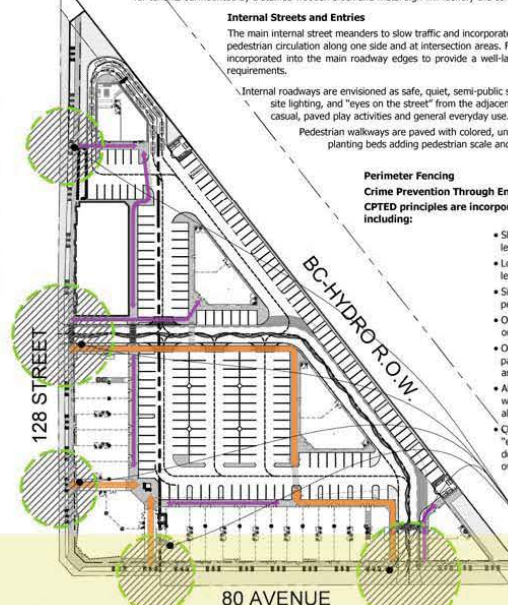

2 PEDESTRIAN CIRCULATION
A0 004 1/8" = 1'-0"

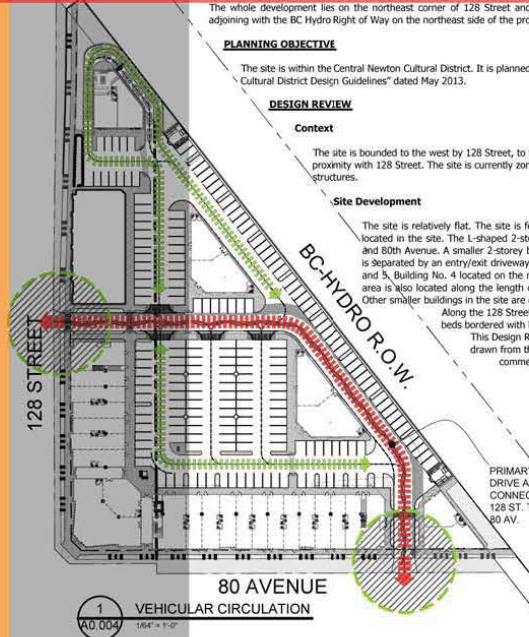

1 VEHICULAR CIRCULATION
A0 004 1/8" = 1'-0"

Form & Character

With keeping in mind the theme as stated in the Central Newton Cultural District Design Guidelines form and character proposed by the new OCP and at the same time being in unity with the existing developments in the area the resulting design blend as well as stand out in its surroundings.

Massing of the building attempts to balance the massing of the adjacent development around the property. The resulting height and mass are in keeping with the nearby development.

The architectural references are a blend of contemporary style with a touch of British Columbia's native material palette as expressed in the use of veneer stone mimicking traditional stone and the use of cedar planks as feature and exterior soffits. The extensive use of canopies over window openings not only lend functional use but reinforce and add dimension to the form and character of the development as per Newton Cultural District Design Guidelines. Building nos. 2 and 3 are intended to be the major building elements that will convey the general form and character of the development. Building no.2, though considered as one building is designed to look in a façade as a combination of attached buildings with different look and appearance at a certain bay and retail facade unit. This form was achieved by form articulation, by offsetting exterior wall plane in and out of the façade line and by treating the wall surface with various colors and material textures.



NOTES:



1	
2	
3	
4	
5	
6	
7	
8	
9	
10	
11	
12	
13	
14	
15	
16	
17	
18	
19	
20	
21	
22	
23	
24	
25	
26	
27	
28	
29	
30	
31	
32	
33	
34	
35	
36	
37	
38	
39	
40	
41	
42	
43	
44	
45	
46	
47	
48	
49	
50	
51	
52	
53	
54	
55	
56	
57	
58	
59	
60	
61	
62	
63	
64	
65	
66	
67	
68	
69	
70	
71	
72	
73	
74	
75	
76	
77	
78	
79	
80	
81	
82	
83	
84	
85	
86	
87	
88	
89	
90	
91	
92	
93	
94	
95	
96	
97	
98	
99	
100	

df
ARCHITECTURE inc.
1205-4871 SHELL ROAD
RICHMOND, BRITISH COLUMBIA
CANADA V6X 3Z6
T: (604) 274-5186 F: (604) 274-5131
info@dfarchitecture.ca

PROJECT:
PROPOSED COMMERCIAL DEVELOPMENT
8020-128 STREET, 12829-80 AVENUE & 12865-80 AVENUE, SURREY, B.C.

CLIENT:
0712680 BC LTD.

SUBMISSION TO ADVISORY DESIGN PANEL ADP MEETING 20th SEPT., 2013
7913-0047-00

CONCEPT RESERVED. THIS PLAN AND DESIGN ARE USED AS ALL PARTS REMAIN THE EXCLUSIVE PROPERTY OF DF ARCHITECTURE INC. AND CANNOT BE REPRODUCED WITHOUT THE ARCHITECT'S WRITTEN CONSENT.

DATE:	2013
CHECKED BY:	
SCALE:	1/8" = 1'-0"
JOB NO.:	808 009
DATE:	22 AUG 2013
SHEET TITLE:	

PEDESTRIAN & VEHICULAR CIRCULATION LAYOUT

DESIGN NO.:	A-004	C
-------------	--------------	----------

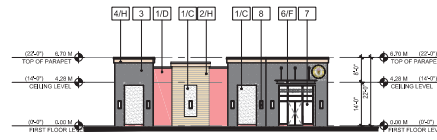
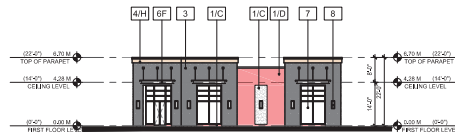
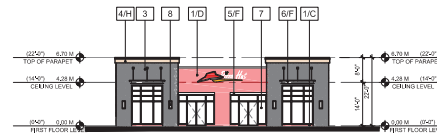
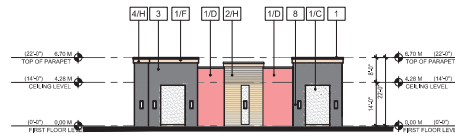
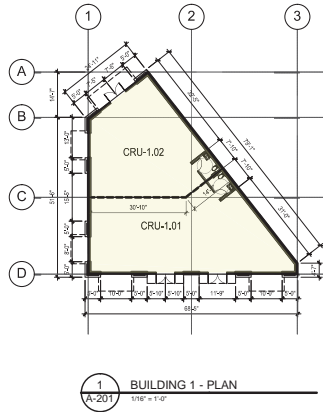

NOTES:

SCHEDULE OF MATERIALS / FINISHES

- 1 TILT-UP STRUCTURAL CONC. WALL
- 2 KAYCAN SHERWOOD SIDING
- 3 STONE VENER CLADDING
- 4 PROFIT ALPINE LEDESTONE BLACK RUNDLE
- 5 PAINTED WOOD FASCIA
- 6 METAL WINDOW CANOPY
- 7 STEEL AND GLASS CANOPY
- 8 DOUBLE GLAZED STOREFRONT WINDOW
- 9 FEATURE WALL LIGHTING
- 10 ANTIHUNG WOODWORKS METAL GRILLE
- 11 COING
- 12 PLUNKTON PLANKS BYTEM CURTAIN WALL WITH PLUNKTON 1988 HIGH EFFICIENCY OPTICAL GLAZING

SCHEDULE OF COLORS

- A - BENJAMIN MOORE 2055-S5 FAIRY TALE BLUE
- B - BENJAMIN MOORE 2018-W6 MACHO CHEESE
- C - BENJAMIN MOORE 2015-W5 TRULY PINK
- D - BENJAMIN MOORE 2005-30 RED TULIP
- E - BENJAMIN MOORE 2014-30 TANGY ORANGE
- F - BENJAMIN MOORE 2130-S0 PLUM HAZE
- G - METAL WOOD 851 CHERRY
- H - DOUBLE COAT CEDAR STAIN

1	A
2	B
3	C
4	D
5	E
6	F
7	G
8	H
9	
10	
11	
12	

df ARCHITECTURE INC.

1205-4871 SHELL ROAD
RICHMOND, BRITISH COLUMBIA
CANADA V6X 3Z6
T: 604.276.5154 F: 604.276.4131
info@dfarchitecture.ca

PROJECT:
PROPOSED COMMERCIAL DEVELOPMENT
8020-128 STREET, 12829-80 AVENUE & 12865-80 AVENUE, SURREY, B.C.

CLIENT:
0712680 BC LTD.

SUBMISSION TO ADVISORY DESIGN PANEL
ADP MEETING 26th SEPT., 2013
7913-0047-00

CONTRACT AGREEMENT: THIS PLAN AND SPECIFICATIONS ARE AT ALL TIMES THE PROPERTY OF DF ARCHITECTURE INC. AND WILL BE KEPT ON FILE AT ALL TIMES WITHOUT THE ARCHITECT'S WRITTEN CONSENT.

DRAWN:	MOHAMED
CHECKED:	
SCALE:	1/8" = 1'-0"
JOB NO.:	808 006
DATE:	30 AUG 2013
SHEET TITLE:	

**BUILDING 1
PLANS & ELEVATIONS**

DRAWING NO.:	A-201	C
---------------------	-------	---

NOTES:

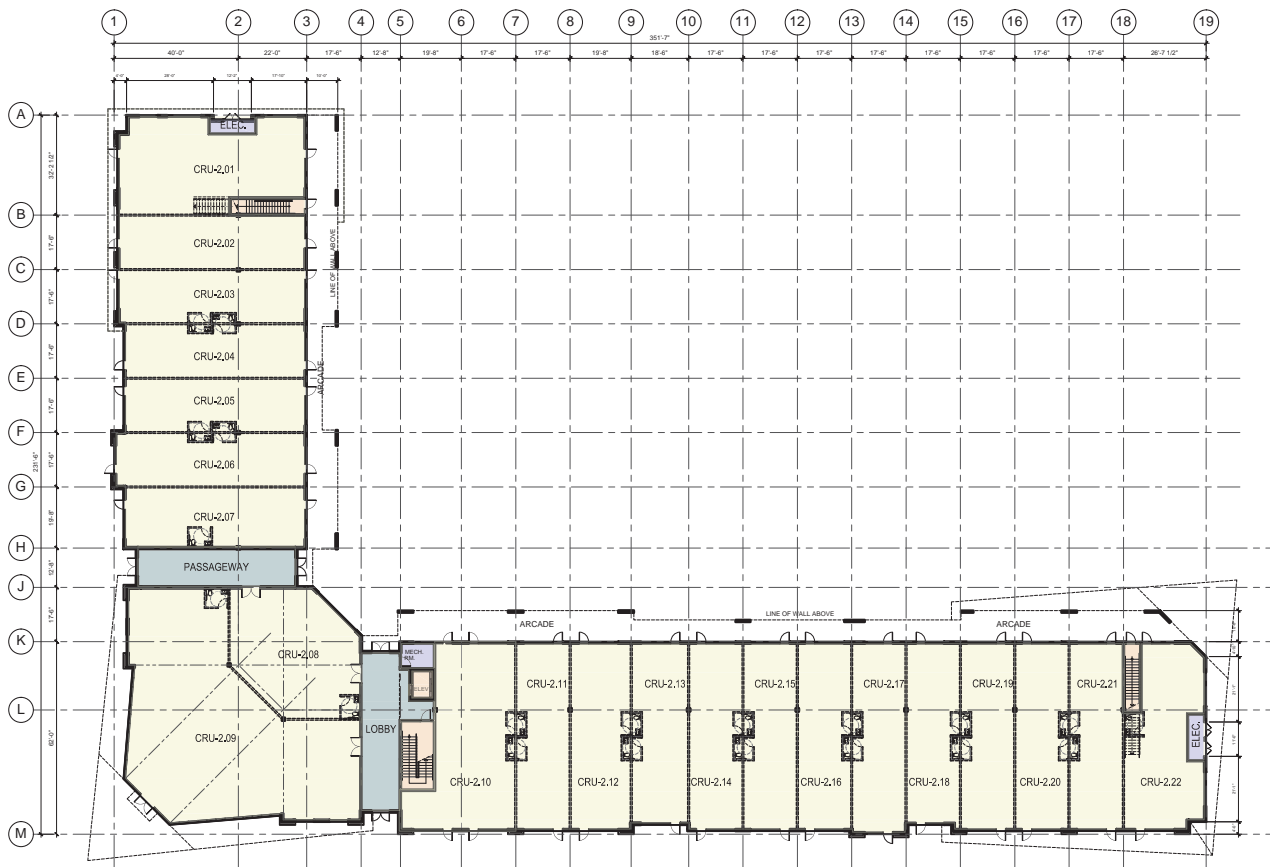

NO.	REVISION
1	
2	
3	
4	
5	
6	
7	
8	
9	
10	
11	
12	
13	
14	
15	
16	
17	
18	
19	
20	
21	
22	
23	
24	
25	
26	
27	
28	
29	
30	
31	
32	
33	
34	
35	
36	
37	
38	
39	
40	
41	
42	
43	
44	
45	
46	
47	
48	
49	
50	
51	
52	
53	
54	
55	
56	
57	
58	
59	
60	
61	
62	
63	
64	
65	
66	
67	
68	
69	
70	
71	
72	
73	
74	
75	
76	
77	
78	
79	
80	
81	
82	
83	
84	
85	
86	
87	
88	
89	
90	
91	
92	
93	
94	
95	
96	
97	
98	
99	
100	



1205-8771 SHELL ROAD
 RICHMOND, BRITISH COLUMBIA
 CANADA V6V 3Z8
 T: (604) 274-5194 F: (604) 274-5131
 info@dfarchitecture.ca

PROJECT:
 PROPOSED COMMERCIAL
 DEVELOPMENT
 8020-128 STREET, 12820-80 AVENUE
 & 12965-80 AVENUE, SURREY, B.C.

CLIENT:

0712680 BC LTD.

SUBMISSION TO
 ADVISORY DESIGN PANEL
 ADP MEETING 28th SEPT., 2013
 7913-0047-00

DISPONENT ADVISED: THIS PLAN AND DESIGN ARE AT ALL TIMES SUBJECT TO THE APPROVAL OF THE ADP AND THE ADP MEETING. ANY CHANGES TO THIS PLAN OR DESIGN MUST BE APPROVED BY THE ADP AND THE ADP MEETING. THE DISPONENT IS RESPONSIBLE FOR OBTAINING ALL NECESSARY PERMITS AND APPROVALS FROM THE LOCAL GOVERNMENT AND OTHER RELEVANT AGENCIES.

DATE:	10 AUG 2013
SHEET TITLE:	

BUILDING 2
 LEVEL 1 FLOOR PLAN

1 BLDG. 2 LEVEL 1 PLAN
 A-202 1/16" = 1'-0"

DRAWING NO.:	A-202	C
--------------	-------	---

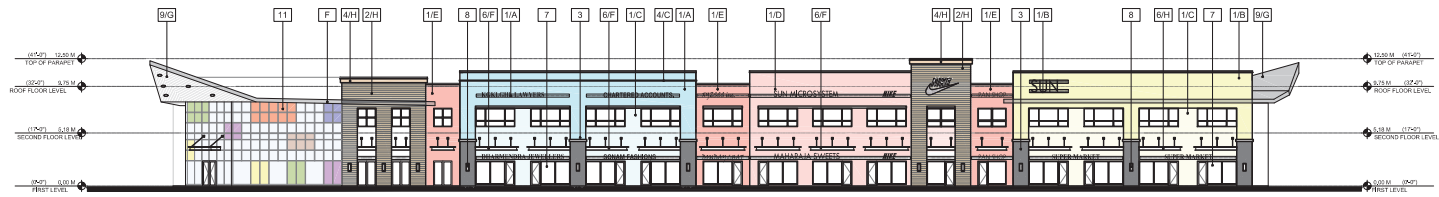

1 SOUTH SIDE ELEVATION
1/8" = 1'-0"

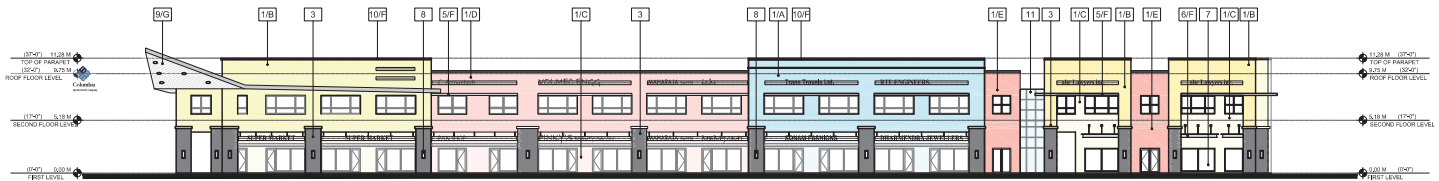

2 NORTH SIDE ELEVATION
1/8" = 1'-0"

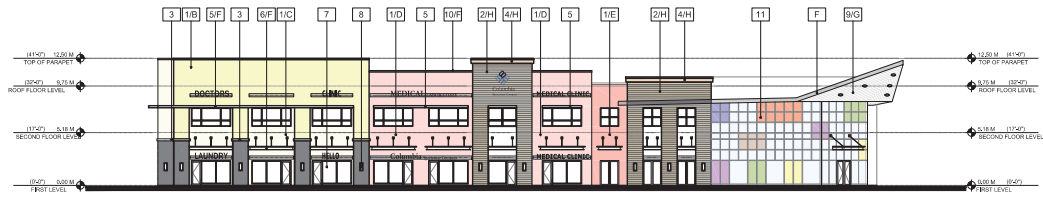

3 WEST SIDE ELEVATION
1/8" = 1'-0"



4 EAST SIDE ELEVATION
1/8" = 1'-0"

NOTES:

SCHEDULE OF MATERIALS/FINISHES

- 1 TILT-UP STRUCTURAL CONC. WALL
- 2 KAYCAN SHERWOOD SIDING
- 3 STONE VENEER CLADDING
- 4 BRUSH ALUMINUM LIGGESTONE BLACK FINALE
- 5 PAINTED WOOD FACIA
- 6 METAL WINDOW CANOPY
- 7 STEEL AND GLASS CANOPY
- 8 DOUBLE GLAZED ALUMINUM WINDOW
- 9 FEATURE WALL LIGHTING
- 10 ARMSTRONG WOODWORKS METAL GRILLE
- 11 COPING
- 12 PILKINGTON PLANAR SYSTEM CURTAIN WALL WITH PILKINGTON 1000 HIGH EFFICIENCY STIPULATED GLAZING

SCHEDULE OF COLORS

- A - BENJAMIN MOORE 2055-50 FAIRY TALE BLUE
- B - BENJAMIN MOORE 2014-40 NACHO CHEESE
- C - BENJAMIN MOORE 2003-40 TRULY PINK
- D - BENJAMIN MOORE 2000-30 RED TULIP
- E - BENJAMIN MOORE 2014-40 TANGY ORANGE
- F - BENJAMIN MOORE 2102-40 PILGRIM HAZE
- G - METAL WOOD #051 CHERRY
- H - DOUBLE COAT CEDAR STAIN

NO.	DESCRIPTION
1	
2	
3	
4	
5	
6	
7	
8	
9	
10	
11	
12	



1205-4571 SHELL ROAD
RICHMOND, BRITISH COLUMBIA
CANADA V6X 3Z8
T 604-284-5194 F 604-284-5131
info@dfarchitecture.ca

PROJECT:
PROPOSED COMMERCIAL
DEVELOPMENT
8020-128 STREET, 12829-80 AVENUE
& 12865-80 AVENUE, SURREY, B.C.

CLIENT:
0712680 BC LTD.

SUBMISSION TO
ADVISORY DESIGN PANEL
ADP MEETING 2008 SEPT., 2013
7913-0047-00

CONTRACT AGREEMENT: THIS PLAN AND DESIGN ARE MADE BY AND FOR THE ARCHITECT AND SHALL BE THE PROPERTY OF THE ARCHITECT. NO PART OF THIS PLAN OR DESIGN SHALL BE REPRODUCED OR TRANSMITTED IN ANY FORM OR BY ANY MEANS, ELECTRONIC OR MECHANICAL, WITHOUT THE WRITTEN PERMISSION OF THE ARCHITECT.

DATE:	2008-09-01
PROJECT:	1/8" = 1'-0"
SCALE:	1/8" = 1'-0"
JOB NO.:	2008-09-01
REV.:	2008-09-01
SHEET TITLE:	

BUILDING 2
ELEVATIONS

DRAWING NO.:
A - 204 C

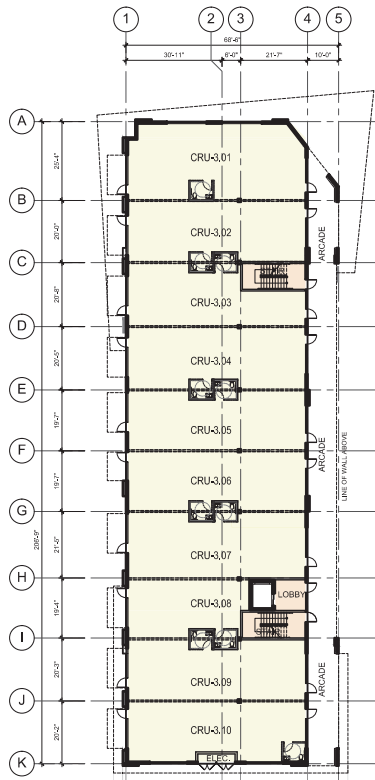

1 BUILDING 3 - FIRST FLOOR PLAN
A-205 1/16" = 1'-0"

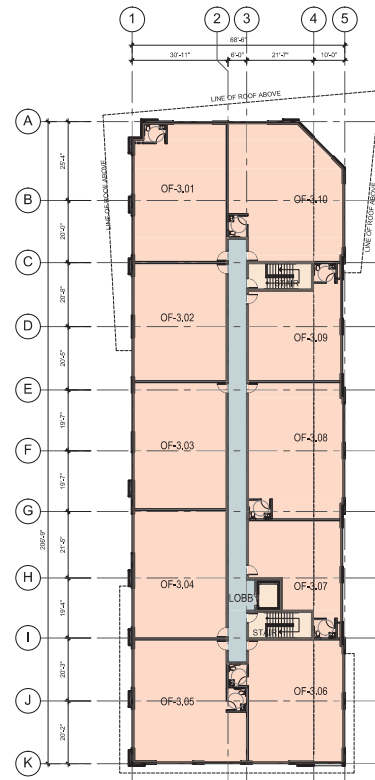

2 BUILDING 3 - SECOND FLOOR PLAN
A-205 1/16" = 1'-0"

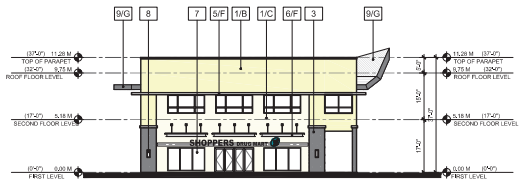

3 SOUTH SIDE ELEVATION
A-205 1/16" = 1'-0"

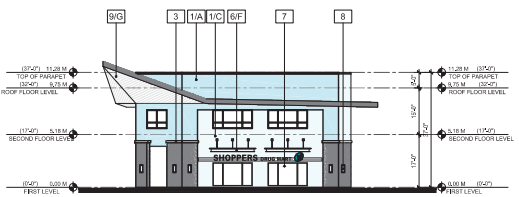

5 NORTH SIDE ELEVATION
A-205 1/16" = 1'-0"

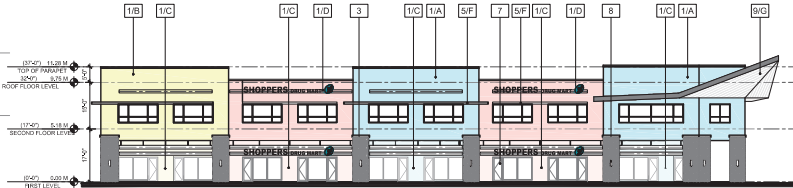

6 EAST SIDE ELEVATION
A-205 1/16" = 1'-0"



4 WEST SIDE ELEVATION
A-205 1/16" = 1'-0"

- NOTES:**
- SCHEDULE OF MATERIALS FINISHES**
- [1] TILT-UP STRUCTURAL CONC. WALL
 - [2] KAYCAN SHERWOOD SIDING
 - [3] STONE VENEER CLADDING
 - [4] WHITE ALUMINE SIDINGSTONE
 - [5] BLACK RUMBLE
 - [6] PAINTED WOOD FACIA
 - [7] METAL WINDOW CANOPY
 - [8] STEEL AND GLASS CANOPY
 - [9] DOUBLE GLAZED SHORPOINT WINDOW
 - [10] FEATURE WALL LIGHTING
 - [11] ARMSTRONG WOODWORKS METAL GRILLE
 - [12] CORING
 - [13] PILKINGTON PLANAR SYSTEM CURTAIN WALL WITH PILKINGTON 1000 HIGH EFFICIENCY SUPPLANT GLAZING

- SCHEDULE OF COLORS**
- A - BENJAMIN MOORE 2055-50 FAIRY TALE BLUE
 - B - BENJAMIN MOORE 2014-40 NACHO CHEESE
 - C - BENJAMIN MOORE 2003-40 TRILE PINK
 - D - BENJAMIN MOORE 2000-30 RED TULIP
 - E - BENJAMIN MOORE 2014-30 TANGY ORANGE
 - F - BENJAMIN MOORE 2102-40 PILGRIM HAZE
 - G - METAL WOOD #051 CHERRY
 - H - DOUBLE COAT CEDAR STAIN

NO.	REVISION	DATE
1	ISSUED FOR PERMIT	2013/09/11
2	ISSUED FOR PERMIT	2013/09/11
3	ISSUED FOR PERMIT	2013/09/11
4	ISSUED FOR PERMIT	2013/09/11
5	ISSUED FOR PERMIT	2013/09/11
6	ISSUED FOR PERMIT	2013/09/11
7	ISSUED FOR PERMIT	2013/09/11
8	ISSUED FOR PERMIT	2013/09/11
9	ISSUED FOR PERMIT	2013/09/11
10	ISSUED FOR PERMIT	2013/09/11
11	ISSUED FOR PERMIT	2013/09/11
12	ISSUED FOR PERMIT	2013/09/11
13	ISSUED FOR PERMIT	2013/09/11
14	ISSUED FOR PERMIT	2013/09/11
15	ISSUED FOR PERMIT	2013/09/11
16	ISSUED FOR PERMIT	2013/09/11
17	ISSUED FOR PERMIT	2013/09/11
18	ISSUED FOR PERMIT	2013/09/11
19	ISSUED FOR PERMIT	2013/09/11
20	ISSUED FOR PERMIT	2013/09/11
21	ISSUED FOR PERMIT	2013/09/11
22	ISSUED FOR PERMIT	2013/09/11
23	ISSUED FOR PERMIT	2013/09/11
24	ISSUED FOR PERMIT	2013/09/11
25	ISSUED FOR PERMIT	2013/09/11
26	ISSUED FOR PERMIT	2013/09/11
27	ISSUED FOR PERMIT	2013/09/11
28	ISSUED FOR PERMIT	2013/09/11
29	ISSUED FOR PERMIT	2013/09/11
30	ISSUED FOR PERMIT	2013/09/11
31	ISSUED FOR PERMIT	2013/09/11
32	ISSUED FOR PERMIT	2013/09/11
33	ISSUED FOR PERMIT	2013/09/11
34	ISSUED FOR PERMIT	2013/09/11
35	ISSUED FOR PERMIT	2013/09/11
36	ISSUED FOR PERMIT	2013/09/11
37	ISSUED FOR PERMIT	2013/09/11
38	ISSUED FOR PERMIT	2013/09/11
39	ISSUED FOR PERMIT	2013/09/11
40	ISSUED FOR PERMIT	2013/09/11
41	ISSUED FOR PERMIT	2013/09/11
42	ISSUED FOR PERMIT	2013/09/11
43	ISSUED FOR PERMIT	2013/09/11
44	ISSUED FOR PERMIT	2013/09/11
45	ISSUED FOR PERMIT	2013/09/11
46	ISSUED FOR PERMIT	2013/09/11
47	ISSUED FOR PERMIT	2013/09/11
48	ISSUED FOR PERMIT	2013/09/11
49	ISSUED FOR PERMIT	2013/09/11
50	ISSUED FOR PERMIT	2013/09/11

df
ARCHITECTURE
INC.

1205-4571 SHELL ROAD
RICHMOND, BRITISH COLUMBIA
CANADA V6X 3Z8
T 604-284-5194 F 604-284-5131
info@dfarchitectures.ca

PROJECT:
PROPOSED COMMERCIAL DEVELOPMENT
8020-128 STREET, 12829-80 AVENUE & 12865-80 AVENUE, SURREY, B.C.

CLIENT:
0712680 BC LTD.

SUBMISSION TO ADVISORY DESIGN PANEL
ADP MEETING 2008 SEPT., 2013
7913-0047-00

CONTRACT NUMBER: THIS PLAN AND DESIGN ARE NOT TO BE USED FOR ANY OTHER PROJECT WITHOUT THE WRITTEN PERMISSION OF THE ARCHITECT.
DESIGNER: df ARCHITECTURE
DATE: 1/16" = 1'-0"
JOB NO.: 08-09
REV.: 26 MAR 2013
SHEET TITLE:

**BUILDING - 3
PLANS & ELEVATIONS**

DRAWING NO.:
A-205 C

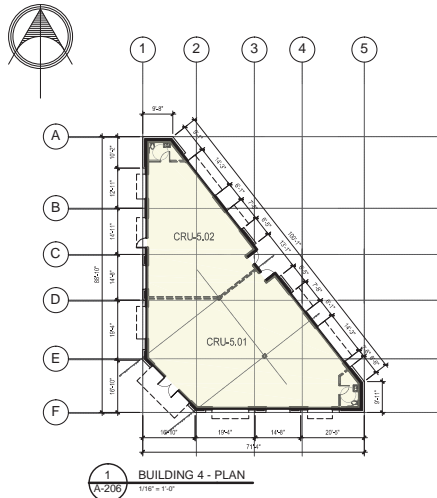

1 BUILDING 4 - PLAN
A-206 1/8" = 1'-0"



2 BUILDING 5 - WEST ELEVATION
A-206 1/8" = 1'-0"



3 BUILDING 5 - SOUTH ELEVATION
A-206 1/8" = 1'-0"



4 BUILDING 5 - EAST ELEVATION
A-206 1/8" = 1'-0"

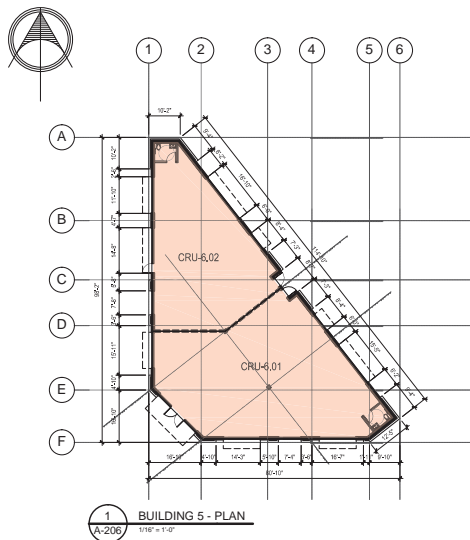

1 BUILDING 5 - PLAN
A-206 1/8" = 1'-0"



2 BUILDING 6 - WEST ELEVATION
A-206 1/8" = 1'-0"

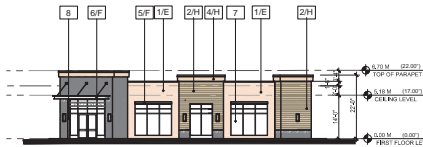

3 BUILDING 6 - SOUTH ELEVATION
A-206 1/8" = 1'-0"



4 BUILDING 6 - EAST ELEVATION
A-206 1/8" = 1'-0"

NOTES:

SCHEDULE OF MATERIALS & FINISHES

- 1 TILT-UP STRUCTURAL CONCRETE WALL
- 2 KAYCAN SHERWOOD SIDING
- 3 STONE VENEER GLAZING
INSULT ALPINE LEDGESTONE
BLACK FINISH
- 4 PAINTED WOOD FASCIA
- 5 METAL WINDOW CANOPY
- 6 STEEL AND GLASS CANOPY
- 7 DOUBLE GLAZED ENERGY EFFICIENT WINDOW
- 8 FEATURE WALL LIGHTING
- 9 ANGSTROM WOODWORK/METAL GRILLE
- 10 COPING
- 11 PLINGTON PLANK SYSTEM CURTAIN WALL
WITH FILMSTRONG 1000 HIGH EFFICIENCY
STIPPLAST GLAZING

SCHEDULE OF COLORS

- A - BENJAMIN MOORE 2055-50 FAIRY TALE BLUE
- B - BENJAMIN MOORE 2018-40 NACHO CHEESE
- C - BENJAMIN MOORE 3003-40 TRULY PINK
- D - BENJAMIN MOORE 3000-30 RED TULIP
- E - BENJAMIN MOORE 2143-30 TANGY ORANGE
- F - BENJAMIN MOORE 2132-50 PILGRIM HAZE
- G - METAL WOOD 8 051 CHERRY
- H - DOUBLE COAT CEDAR STAIN

	W	E	N	S
2013/11/01	C	REVISED TO LAYOUT OF BUILDING 3		
2013/10/01	B	REVISED AS / PER SUBMISSION NO. 8		
2013/09/11	A	PER PLAN		



1205-4871 SHELL ROAD
RICHMOND, BRITISH COLUMBIA
CANADA V6V 3Z6
T: (604) 264-5184 F: (604) 264-5131
info@dfcarchitecture.ca

PROJECT:
PROPOSED COMMERCIAL
DEVELOPMENT
8020-128 STREET, 12820-80 AVENUE
& 12865-80 AVENUE, SURREY, B.C.

DATE:

07/12/2013 BC LTD.

SUBMISSION TO
ADVISORY DESIGN PANEL
ADP MEETING 28th SEPT., 2013
7913-0047-00

DISPANY ADVISED: THIS PLAN AND DESIGN ARE AT ALL TIMES SUBJECT TO REVIEW & APPROVAL BY ARCHITECTURE REGULATORY BOARD. REVISIONS SHALL BE MADE TO REFLECT CHANGES.

DATE:	2013
REVISION:	
SCALE:	A.S.
JOB NO.:	047-000
DATE:	12 AUG. 2013
SHEET TITLE:	

**BUILDING 5 & 6
PLANS & ELEVATIONS**

DRAWING NO.:	A-206	C
---------------------	-------	---

NOTES:

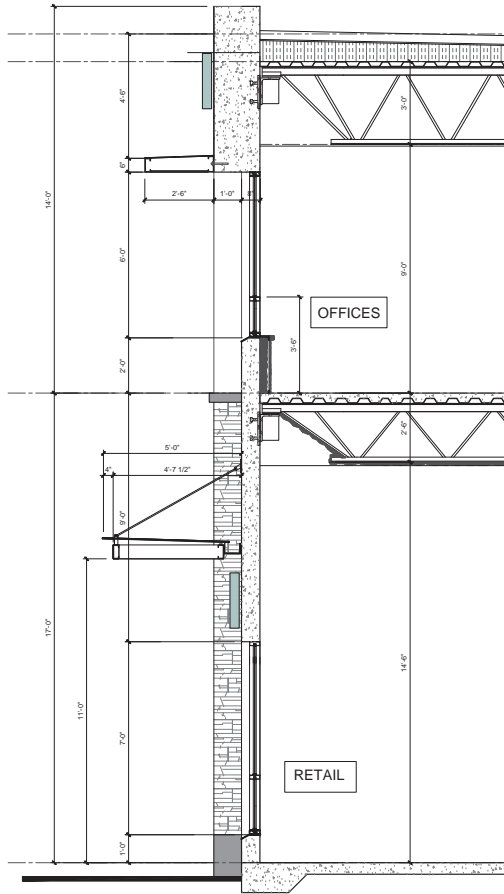

5 TYP. WALL SECTION ALONG STREET
A-501 1/8" = 1'-0" 2-STORY RETAIL & OFFICES

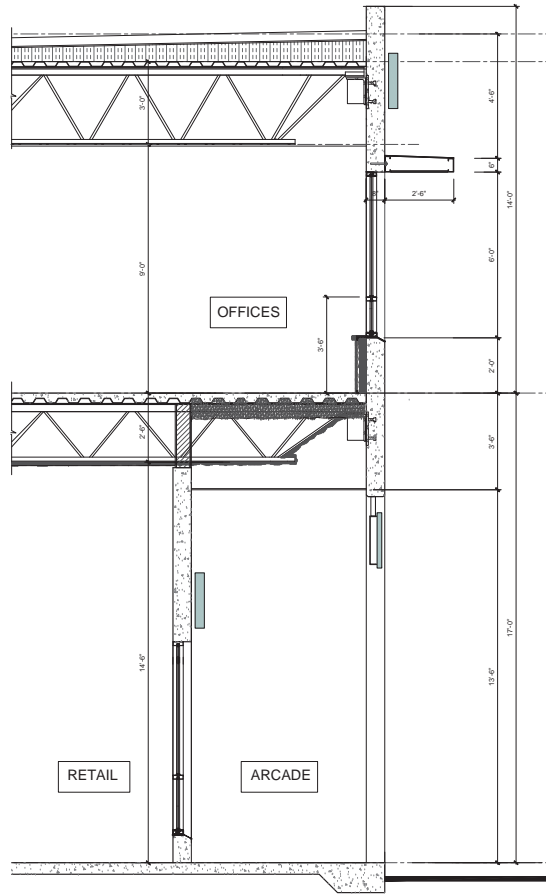

5 TYP. WALL SECTION FACING PARKING AREA
A-501 1/8" = 1'-0" 2-STORY RETAIL & OFFICES

NO.	DATE	DESCRIPTION
1	2013/09/02	A FOR ADP SUBMISSION
2	2013/09/02	B FOR ADP SUBMISSION
3	2013/10/08	B REVISION AS / ADP SUBMISSION REQ.
4	2013/11/13	C REVISION TO LAYOUT OF BUILDING 3

df
ARCHITECTURE
inc.

1205-4871 SHELL ROAD
RICHMOND, BRITISH COLUMBIA
CANADA V6X 3Z6
T (604)284-5194 F (604)284-5131
info@dfarchitecture.ca

PROJECT:
PROPOSED COMMERCIAL DEVELOPMENT
8020-128 STREET, 12829-80 AVENUE & 12865-80 AVENUE, SURREY, B.C.

CLIENT:
0712680 BC LTD.

SUBMISSION TO
ADVISORY DESIGN PANEL
ADP MEETING 26th SEPT., 2013
7913-0047-00

COPYRIGHT RESERVED. THIS PLAN AND DESIGN ARE AND AT ALL TIMES REMAIN THE EXCLUSIVE PROPERTY OF DF ARCHITECTURE INC. AND CHANGE IS TO BE REPRODUCED WITHOUT THE ARCHITECT'S WRITTEN CONSENT.

DRAWN:	JBL
CHECKED:	
SCALE:	A.S.
JOB No.:	SUR 000
DATE:	02 AUG. 2013
SHEET TITLE:	

TYPICAL
WALL SECTIONS

DRAWING NO.:	A-502	C
--------------	-------	---

FOR ALL SURVEY AND/OR MEASUREMENTS USE THE PROVIDED DIMENSIONS

NOTES:

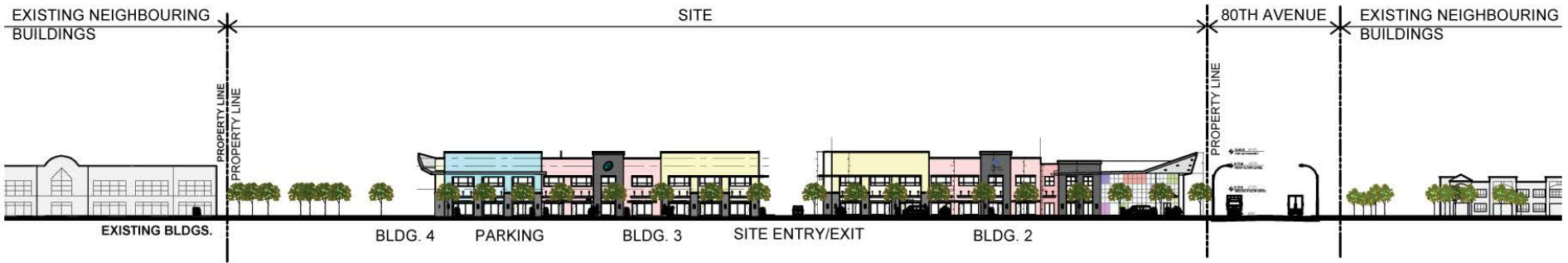

1 STREETScape ELEVATION ALONG 128TH STREET
 A-301 1/32" = 1'-0"



2 STREETScape ELEVATION ALONG 80TH AVENUE
 A-301 1/32" = 1'-0"

H	
N	
F	
E	
D	
C	
B	
A	
1	ISSUED TO LAYOUT OF BLDG 2
2	ISSUED FOR / ADP SUBMISSION
3	FOR ADP SUBMISSION

df
 inc.

1205-4871 SHELL ROAD
 RICHMOND, BRITISH COLUMBIA
 CANADA V6V 3Z9
 T:(604)284-5194 F:(604)284-5131
 info@dfarchitecture.ca

PROJECT:
 PROPOSED COMMERCIAL
 DEVELOPMENT
 8020-128 STREET, 12828-80 AVENUE
 & 12865-80 AVENUE, SURREY, B.C.

CLIENT:
 0712680 BC LTD.

SUBMISSION TO
 ADVISORY DESIGN PANEL
 ADP MEETING 20th SEPT., 2013
 7913-0047-00

COPYRIGHT RESERVED. THIS PLAN AND DESIGN ARE, AND AT ALL
 TIMES REMAIN THE EXCLUSIVE PROPERTY OF DF ARCHITECTURE
 INC. AND CANNOT BE USED OR REPRODUCED WITHOUT THE
 ARCHITECT'S WRITTEN CONSENT.

DRAWN:	JDB
CHECKED:	
SCALE:	1/16" = 1'-0"
JOB No.:	SUR 009
DATE:	02 APR. 2013
SHEET TITLE:	

STREETScape
 ELEVATIONS

DRAWING NO.:	A-301	C
--------------	-------	---

DATE PLOTTED: 08/08/2013 10:58:00 AM

NOTES:

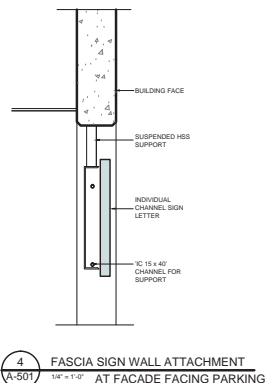
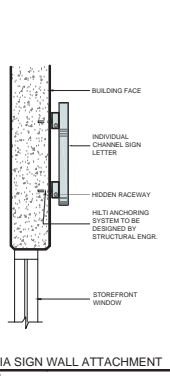
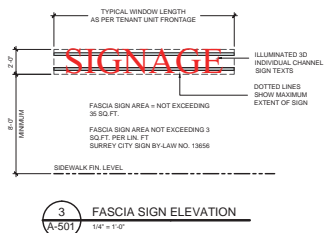
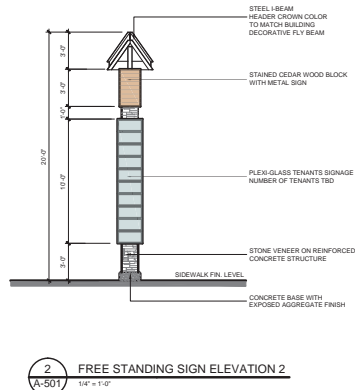
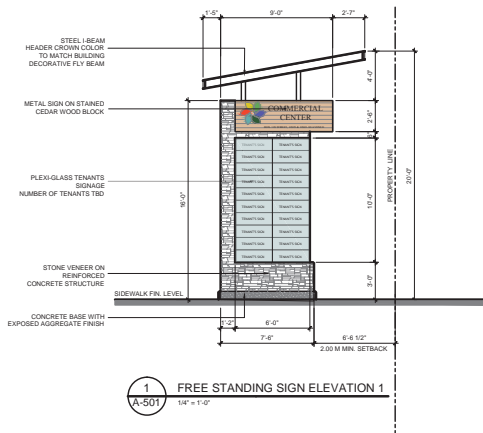

	H
	D
	F
	E
	B
08/17/13	C - REVIEW TO VERIFY OF BUILDING 3
08/17/13	B - REVIEW AS / NOT SUBMITTED YES
08/16/13	A - FOR APPROVAL

df
ARCHITECTURE
inc.

1205-8771 SHELL ROAD
RICHMOND, BRITISH COLUMBIA
CANADA V6V 3Z6
T: (604) 274-5104 F: (604) 274-5131
info@dfarchitecture.ca

PROJECT:
PROPOSED COMMERCIAL
DEVELOPMENT
8020-128 STREET, 12829-80 AVENUE
& 12965-80 AVENUE, SURREY, B.C.

CLIENT:
0712680 BC LTD.
SUBMISSION TO
ADVISORY DESIGN PANEL
ADP MEETING 28th SEPT., 2013
7913-0047-00

DISCLAIMER: THESE PLANS AND DESIGN ARE AT ALL TIMES SUBJECT TO THE APPROVAL OF THE LOCAL AUTHORITY AND THE PROFESSIONAL ARCHITECTURE BOARD OF BRITISH COLUMBIA.

OWNER:	
DESIGNER:	
SCALE:	A.S.
DWG NO.:	049 009
DATE:	10 AUG. 2013
SHEET TITLE:	

SIGNAGE
DETAILS

DRAWING NO.:	
A-501	C

NOTES:



1 SHADOW STUDY ON 21st MARCH AT 3.00PM
A-601 NTS



2 SHADOW STUDY ON 21st JUNE AT 3.00PM
A-601 NTS



3 SHADOW STUDY ON 21st SEPTEMBER AT 3.00PM
A-601 NTS



4 SHADOW STUDY ON 21st DECEMBER AT 3.00PM
A-601 NTS

	H
	D
	F
	E
	S
2013/1/13	C REVISION TO LAYOUT OF BUILDING 3
2013/10/23	B REVISION AS / NOT SUBMITTED YET.
2013/06/11	A FOR AIP SUBMISSION

df
ARCHITECTURE
inc.

1205-4871 SHELL ROAD
RICHMOND, BRITISH COLUMBIA
CANADA V6V 3Z8
T: (604) 284-5184 F: (604) 284-5131
info@dfarchitecture.ca

PROJECT:
PROPOSED COMMERCIAL
DEVELOPMENT
8020-128 STREET, 12820-80 AVENUE
& 12865-80 AVENUE, SURREY, B.C.

CLIENT:
0712680 BC LTD.

SUBMISSION TO
ADVISORY DESIGN PANEL
ADP MEETING 28th SEPT., 2013
7913-0047-00

COPYRIGHT RESERVED. THIS PLAN AND DESIGN ARE AT ALL
TIMES THE PROPERTY OF ARCHITECTURE INC. NO PART OF
THIS DOCUMENT IS TO BE REPRODUCED OR TRANSMITTED
IN ANY FORM OR BY ANY MEANS WITHOUT THE WRITTEN
CONSENT OF ARCHITECTURE INC.

DATE:	14
REVISION:	
SCALE:	A3
JOB NO.:	0047-000
SHEET:	10 AUG 2013

SHEET TITLE:

SHADOW STUDY

DRAWING NO.:

A-601

C



ARIEL VIEW OF PROPOSED DEVELOPMENT



PERSPECTIVE AT INTERSECTION OF 128th ST. & 80th AVE.

COMMERCIAL DEVELOPMENT

8020 - 128 St, 12829 - 80 Av & 12865 - 80 Av, SURREY, BRITISH COLUMBIA



©Copyright reserved. This drawing and design is the property of M2 Landscape Architects and may not be reproduced or used for other projects without their permission.



#220 - 26 Lorne Mews
 New Westminster, British Columbia
 V3M 3L7
 Tel: 604.553.0044
 Fax: 604.553.0045
 Email: office@m2la.com

NO.	DATE	REVISION DESCRIPTION	DR.

OF BLDGS REV. PER NEW SITE PLAN QL
 NO. DATE REVISION DESCRIPTION DR.

SEALED:

PROJECT:
COMMERCIAL DEV.
 8020 128 ST.
 SURREY, BC

DRAWING TITLE:
**LANDSCAPE
 CONCEPT PLAN**

DATE: 13-SEP-24 DRAWING NUMBER:
 SCALE: 1/8"=1'-0" DRAWN: GL
 DESIGN: GL
 CHECK: GL

L1

OF 4

M2LA PROJECT NUMBER: 13-043

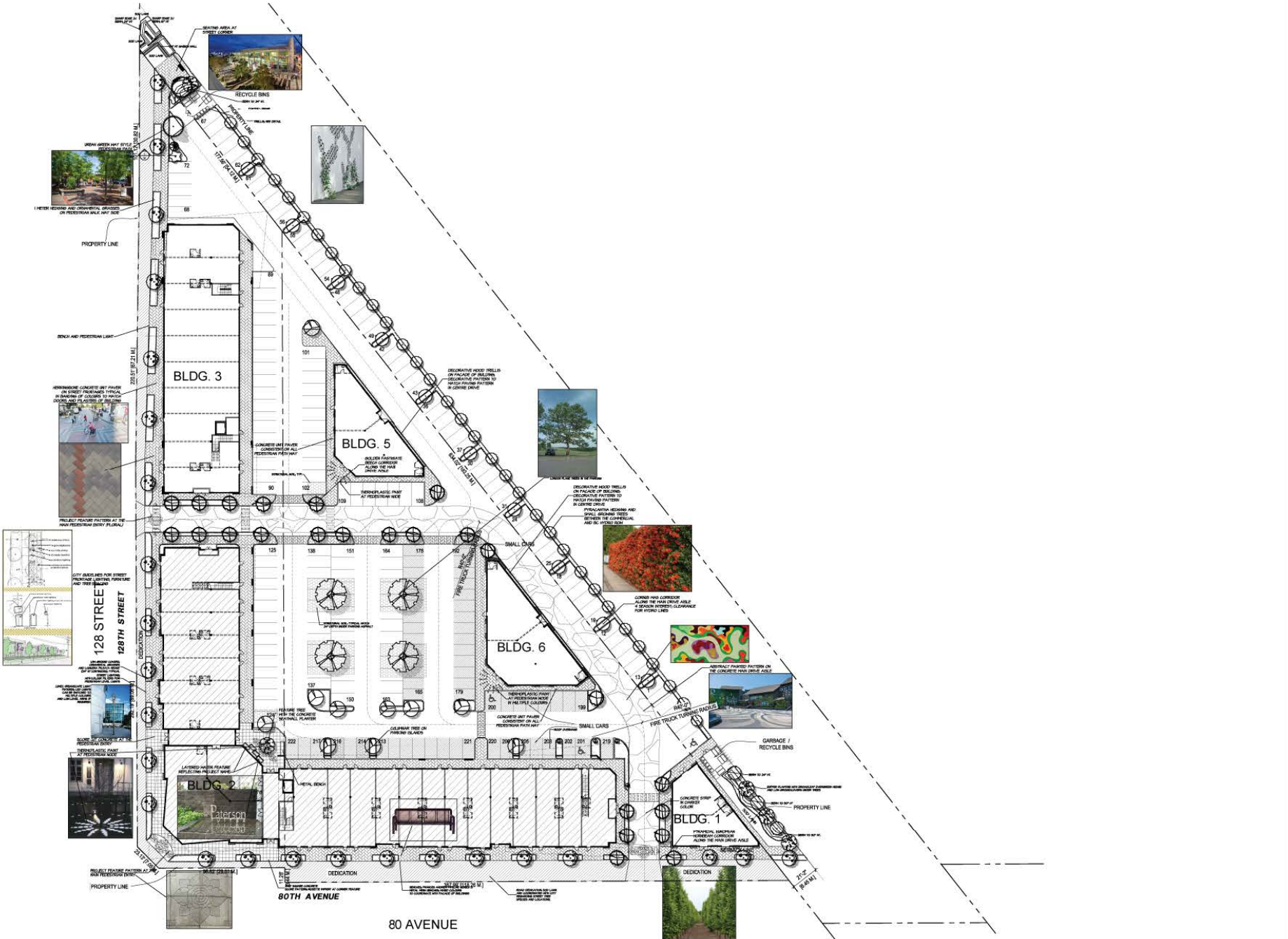



#220 - 26 Lorne Mevs
New Westminister, British Columbia
V3M 3L7
Tel: 604.553.0044
Fax: 604.553.0045
Email: office@m2la.com

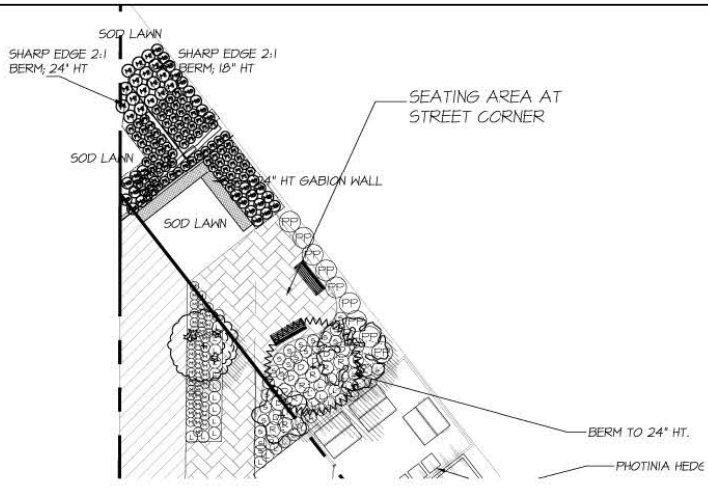

ENLARGEMENT: PLANTING PLAN AT NORTH CORNER
SCALE: 1"=5'-0"

PLANT SCHEDULE				M2 JOB NUMBER	IS-043
KEY	CITY	BOTANICAL NAME	COMMON NAME	PLANTED SIZE / REMARKS	
L		LONGERA PILEATA	BOX HORSETAIL	42 POT, 5004	
PP		PHOTINIA X FRASERA	PHOTINIA	10 POT, 6504	
G		GRASS			
D		DESCHAMPSIA CASPITOSA AGLODITAI	TUFTED HAIR GRASS	10 POT	
H		HOLNIA CABELLA VARIEGATA	VARIEGATED MOOR GRASS	10 POT	
PER		PERENNA			
K		RUDEBECKIA FLUIDA VAR S. SOLIDUM	RUDEBECKIA	10 POT	
S		SEDUM AUTUMN JOY	SEDUM	10 POT	

NOTES: * PLANT SIZES IN THIS LIST ARE SPECIFIED ACCORDING TO THE BC LANDSCAPE STANDARD, LATEST EDITION. CONTAINER SIZES SPECIFIED AS PER ONTA STANDARDS. BOTH PLANT SIZE AND CONTAINER SIZE ARE THE MINIMUM ACCEPTABLE SIZES. * REFER TO SPECIFICATIONS FOR DEFINED CONTAINER MEASUREMENTS AND OTHER PLANT MATERIAL REQUIREMENTS. * SEARCH AND REVIEW: MAKE PLANT MATERIAL AVAILABLE FOR OPTIONAL REVIEW BY LANDSCAPE ARCHITECT AT SOURCE OF SUPPLY. AREA OF SEARCH TO INCLUDE LOWER MAINLAND AND FRASER VALLEY. * SUBSTITUTIONS: OBTAIN WRITTEN APPROVAL FROM THE LANDSCAPE ARCHITECT PRIOR TO MAKING ANY SUBSTITUTIONS. TO THE SPECIFIED MATERIAL. UNAPPROVED SUBSTITUTIONS WILL BE REJECTED. ALLOW A MINIMUM OF FIVE DAYS PRIOR TO DELIVERY FOR REQUEST TO SUBSTITUTE. SUBSTITUTIONS ARE SUBJECT TO BC LANDSCAPE STANDARD - DEFINITION OF CONDITIONS OF AVAILABILITY.

ALL PLANT MATERIAL MUST BE PROVIDED FROM CERTIFIED DISEASE FREE NURSERY. PROVIDE CERTIFICATION UPON REQUEST.

PLANT SCHEDULE				M2 JOB NUMBER	IS-043
KEY	CITY	BOTANICAL NAME	COMMON NAME	PLANTED SIZE / REMARKS	
26		ACER GINNALA 'FLAME'	FLAME ASH MAPLE	25H HT, 1.6M STD, 64B	
25		CARPINUS BETULUS 'FASTIGIATA'	PYRAMIDAL EUROPEAN HORNBEECH	60H CAL, 1.6M STD, 64B	
28		CAMMERTOPHOS NOTKATENSIS 'PENDULA'	WEEDING NOTKODA CYPRESS	3M HT, 64B	
24		CORNUS MAS	CORNELIAN CHERRY	60H CAL, 1.6M STD, 64B	
27		FRAXINUS CORYMBOSA 'RATHOOD'	RATHOOD ASH	60H CAL, 1.6M STD, 64B	
29		GRUNGO BILGUA 'PRINCETON SENTRY'	PRINCETON SENTRY HADENHAIR	60H CAL, 2.1M STD, 64B	
26		MAGNOLIA SEBOLDII	OTAWA MAGNOLIA	25H HT, MULTISTEM, 64B	
27		MAGNOLIA SOULANGIANA 'ALEXANDRINA'	ALEXANDRINA MAGNOLIA	3M HT, MULTISTEM, 64B	
28		PICEA FRANKERSI 'SLUGA KOSTER'	KOSTER BLUE SPRUCE	2.5M HT, 64B	
29		PSUEDOTSUGA HENZESII	DOUGLAS FIR	3M HT, 64B	
24		VIBURNUM X BURKWOODII	BURKWOOD VIBURNUM FRAGRANT PINK	10 POT, 2H HT.	

NOTES: * PLANT SIZES IN THIS LIST ARE SPECIFIED ACCORDING TO THE BC LANDSCAPE STANDARD, LATEST EDITION. CONTAINER SIZES SPECIFIED AS PER ONTA STANDARDS. BOTH PLANT SIZE AND CONTAINER SIZE ARE THE MINIMUM ACCEPTABLE SIZES. * REFER TO SPECIFICATIONS FOR DEFINED CONTAINER MEASUREMENTS AND OTHER PLANT MATERIAL REQUIREMENTS. * SEARCH AND REVIEW: MAKE PLANT MATERIAL AVAILABLE FOR OPTIONAL REVIEW BY LANDSCAPE ARCHITECT AT SOURCE OF SUPPLY. AREA OF SEARCH TO INCLUDE LOWER MAINLAND AND FRASER VALLEY. * SUBSTITUTIONS: OBTAIN WRITTEN APPROVAL FROM THE LANDSCAPE ARCHITECT PRIOR TO MAKING ANY SUBSTITUTIONS. TO THE SPECIFIED MATERIAL. UNAPPROVED SUBSTITUTIONS WILL BE REJECTED. ALLOW A MINIMUM OF FIVE DAYS PRIOR TO DELIVERY FOR REQUEST TO SUBSTITUTE. SUBSTITUTIONS ARE SUBJECT TO BC LANDSCAPE STANDARD - DEFINITION OF CONDITIONS OF AVAILABILITY.

ALL PLANT MATERIAL MUST BE PROVIDED FROM CERTIFIED DISEASE FREE NURSERY. PROVIDE CERTIFICATION UPON REQUEST.

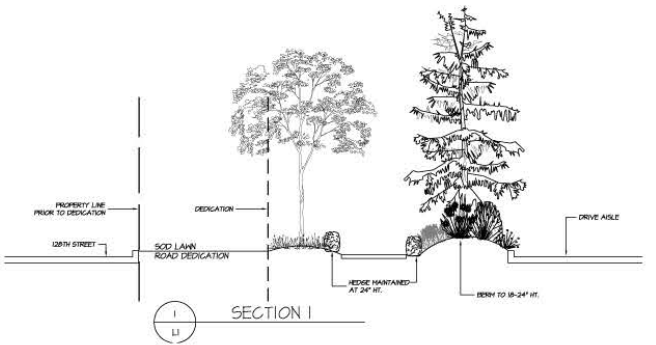
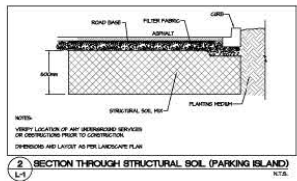

SECTION I: PLANTING AT 128TH STREET; TYP.
SCALE: 1"=5'-0"

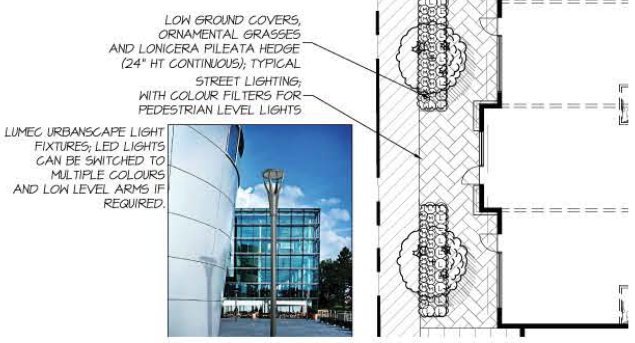

ENLARGEMENT: PLANTING TYP. AT BUILDING FACE
SCALE: 1"=5'-0"

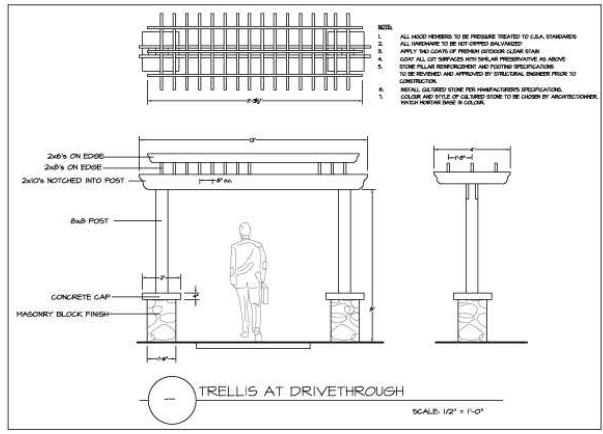

NO	DATE	REVISION DESCRIPTION	DR.

PROJECT:
COMMERCIAL DEV.
8020 128 ST.
SURREY, BC

DRAWING TITLE:
LANDSCAPE DETAILS

DATE: 13SEP24
SCALE: VARIES
DRAWN: GL
DESIGN: GL
CHECK:

DRAWING NUMBER:
L2
OF 4

M2A PROJECT NUMBER: 13-043

TO: **Manager, Area Planning & Development
- South Surrey Division
Planning and Development Department**

FROM: **Development Services Manager, Engineering Department**

DATE: **November 19, 2013** PROJECT FILE: **7813-0047-00**

RE: **Engineering Requirements (Commercial/Industrial)
Location: 8020 - 128 Street & 8020 - 128 Street**

OCP AMENDMENT

There are no engineering requirements relative to the OCP Amendment.

REZONE/CONSOLIDATION

Property and Right-of-Way Requirements

- dedicate various widths from 2.100 metres to 3.455 metres fronting 128 Street for a 30.00 metre arterial standard.
- dedicate various widths from 1.500 metres to 4.942 metres fronting 80 Avenue for a 30.00 metre arterial standard.
- provide 0.5 metre SRWs fronting 128 Street and 80 Avenue.
- provide 5.0m x 5.0m corner cut at the intersection of 128 Street and 80 Avenue.

Works and Services

- construct beautification elements within boulevards fronting 128 Street and 80 Avenue.
- construct a 12.0 metre Bus bay on 128 Street.
- provide a southbound turning lane on 128 Street.
- Register Stormwater Servicing and Access restriction Restrictive Covenants.

A Servicing Agreement is required prior to Rezone/Consolidation.

DEVELOPMENT PERMIT

There are no engineering requirements relative to issuance of the Development Permit.

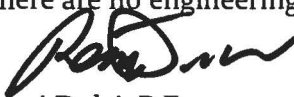
Remi Dubé, P.Eng.
Development Services Manager

LR

NO: **R157**

COUNCIL DATE: **July 9, 2012**

REGULAR COUNCIL

TO: **Mayor & Council**

DATE: **July 9, 2012**

FROM: **General Manager, Planning and Development**

FILE: **6520-20 (Central Newton
Cultural Commercial District)**

SUBJECT: **Establishment of a Central Newton Cultural Commercial District**

RECOMMENDATION

The Planning and Development Department recommends that Council:

1. Receive this report as information;
2. Approve the initiation by staff of a planning process to establish a Central Newton Cultural Commercial District (CNCCD) that will include the following:
 - (a) An Official Community Plan re-designation from "Industrial" to "Commercial" of the area that is outlined on the map, which is attached as Appendix I to this report;
 - (b) The development of design guidelines to ensure that appropriate cultural elements are incorporated into the design and development of sites in the CNCCD with a view to elevating the overall design and architectural quality of the area;
 - (c) The possible establishment of a Business Improvement Area (BIA) for the new commercial district to support its on-going vibrancy;
 - (d) The introduction of a Neighbourhood Concept Plan-type amenity contribution scheme to fund enhancements to the public realm in the CNCCD, which would include enhanced streetscapes, improved pedestrian connectivity and other public amenities; and
 - (e) A public consultation process regarding the above-listed matters; and
3. Authorize the City Clerk to bring forward for the required readings an amending by-law to Surrey Zoning Bylaw, 1993, No. 12000 to introduce a new "Business Park 3 (IB-3) Zone" as generally described in this report, which will support and regulate future business park development in the City.

INTENT

The purpose of this report is to discuss the potential for expansion of commercial uses in the Newton industrial area and to obtain approval to undertake a process to create a Central Newton Cultural Commercial District ("CNCCD") and to introduce a new Business Park 3 (IB-3) Zone.

BACKGROUND

Application No. 7906-0121-00 (Punjab Cloth House)

At its Regular Council Land Use meeting on April 12, 2010, Council considered Development Application No. 7906-0121-00 related to the redevelopment of the property located at the northwest corner of 80 Avenue and 128 Street. The development application included an Official Community Plan ("OCP") amendment from the "Industrial" designation to the "Commercial" designation and a rezoning, land use contract discharge, and development permit to allow the construction of four commercial/retail buildings including a banquet hall (see Appendix II).

After considering the application Council authorized staff to prepare terms of reference for undertaking a planning study of the area along 128 Street both north and south of 80 Avenue with a focus on defining a new CNCCD and including a fulsome public consultation process. Council deferred further consideration of Development Application No. 7906-0121-00 and any other commercial/retail-related applications in the study area pending completion of the planning study.

Emerging Commercial/Retail Businesses on 128 Street

In 2003, Council adopted a policy, City Policy No. O-47 (copy attached as Appendix III), to address the ongoing pressure to rezone "Industrial-designated" lands in the vicinity of 128 Street and 84 Avenue for commercial uses. The Policy stipulated that the City would not support rezoning, including rezoning to Comprehensive Development (CD) Zones, for the purpose of allowing commercial uses in this area. Despite this Policy the number of commercial and retail businesses on 128 Street in the vicinity of 80 Avenue has continued to grow since 2003.

Lands on both sides of 128 Street, between 76 Avenue and 88 Avenue, are designated "Industrial" in the OCP and "General Industrial" in the Newton Local Area Plan. Many properties in this area are zoned "Business Park (IB) Zone" or "Comprehensive Development (CD) Zone", based on either the IB Zone or the "Light Impact Industry (IL) Zone". On a number of these properties, commercial businesses have evolved even though the lands were intended to be developed as industrial and business park sites. The largest concentration of commercial businesses is in the immediate area of the intersection of 128 Street and 80 Avenue.

Upon examining the zones and land uses of these sites, two factors appear to have contributed to the large number of commercial businesses in the area; these being:

- the "accessory retail sales" use that is permitted in the IB Zone; and
- the provision for "retail commercial" uses in some of the Comprehensive Development Zones that apply to lots in the area.

The IB Zone allows for accessory retail sales as long as the products being sold are manufactured or warehoused on the lot and the area used for retail uses is less than the area used for

manufacturing or warehousing uses on the same lot. This provision can be confusing to business owners and is very difficult for City staff to enforce. Some CD-zoned sites in this area allow some retail uses provided that they are limited to a small percentage of the total floor area on the site. It is difficult for business owners (existing or prospective) to know whether the maximum area for retail uses has been reached, especially on strata-titled sites where there is no overall coordinated management of the site. Maintaining an accurate record of such business licenses is also challenging for City staff.

When retail commercial businesses become a significant component of a site, other commercial-oriented businesses are attracted to the area. Medical offices, beauty salons, travel agencies, eating establishments, and other types of service uses, while not strictly retail in nature, change the character of a development. This change can be so significant that the site no longer supports industrial activities, functioning instead as a commercial shopping and service centre. This has happened on some of the sites that front on 128 Street both north and south of 80 Avenue.

DISCUSSION

The expansion of commercial uses within the 128 Street industrial area is challenging in four specific areas as follows:

- Traffic and parking management;
- Building design and site aesthetics;
- Economic fairness; and
- Administrative challenges.

Each of these areas is discussed in more detail in the following sections of this report.

Traffic and Parking Management

Commercial development typically generates approximately four times the vehicular traffic of the same area of industrial development. As a result, the Surrey Zoning By-law, 1993, No. 12000 requires more parking spaces for commercial uses than for industrial uses. Parking deficiencies typically occur when a site that was been developed to industrial standards becomes occupied by commercial uses. Access requirements may also be different for commercial uses in comparison to industrial uses based on the higher traffic volumes generated by commercial uses.

Design and Appearance of Commercial-Oriented Developments on 128 Street

The lands fronting on 128 Street to the north and south of 80 Avenue are designated for industrial uses. As such, industrial design standards have been applied to those developments that have been completed in the area. The existing buildings have an industrial character with limited articulation, limited decorative features and minimal architectural detailing. They also have limited landscaping and extensive signage. In general, there are few sidewalks and minimal formal pedestrian connections.

Economic Comparison of Industrial Development and Commercial Development

Land Value and Lease Rates

"Industrial"-designated land is typically less expensive to purchase than "Commercial"-designated land. A considerable lift in value has occurred for those properties fronting 128 Street in the vicinity of 80 Avenue that have been developed with commercial uses. The estimated value for raw industrial land on 128 Street in Newton is \$25 per square foot while the estimated value of commercial land in the same area is approximately \$50 per square foot. The lease rates for commercial tenancies are significantly higher than for industrial tenancies. The commercial lease rates on 128 Street are comparable to the commercial lease rates being achieved for properties on Scott Road and on King George Boulevard in the Newton Town Centre.

Development Cost Charges (DCCs)

The DCC rates for industrial development are significantly lower than the rates for commercial development. For example, the DCC charges for a 2.5 acre site with a two-storey, 60,000 square foot building would be:

- For industrial development = \$208,300
- For commercial development = \$444,000

Since the land in the vicinity of 128 Street and 80 Avenue is designated for industrial development and zoned primarily for industrial uses. The developers of buildings in the area have been paying DCCs at the industrial rate even though some of the developments in the area are largely commercial retail in nature. This has created an unequal playing field in relation to other commercial development in Newton.

Complex Business Licence Administration

The Business Park (IB) Zone and some of the Comprehensive Development (CD) Zones that are in place on 128 Street both north and south of 80 Avenue are challenging to administer. In some cases, business licences must be classified and tracked on a strata-unit and strata-unit basis within a development by floor area to ensure that commercial uses do not exceed specific floor area caps that are contained within the Zoning of the site. When commercial and service uses are inter-mixed with industrial uses it becomes problematic for City staff to administer and for current and prospective owners/tenants to understand.

Further complicating the administration of business licences is the number of businesses that have been established that are either operating without a business licence or are operating contrary to the business license that was issued by the City for the specific site or unit. Such businesses are in majority retail or commercial in nature, which is adding to the commercial character of the area.

Optional Approaches for Addressing the Current Issues

Two options have been studied and evaluated in relation to resolving the above-discussed issues. These options are discussed in the following sections.

Option 1: Maintain and Enforce the Current Zoning

Under this option staff would undertake active enforcement of the existing zoning regulations applicable to the sites in the subject area and not support any further rezoning in the area that would allow for expanded commercial uses.

Pros:

- Current policies and zoning regulations would not need to be adjusted.

Cons:

- By-law enforcement will continue to be challenging due to the complexities related to the current zones that are in place in the area and will be very time-consuming for staff;
- The City would continue to experience pressure from developers and land owners to allow more commercial uses in the area in consideration of the success of the current uses in satisfying a cultural market niche; and
- The aesthetics of the developments in the subject area in relation to both building and site design would not improve.

Option 2: Develop a Commercial Precinct

Under this option, the City would redesignate a defined area along 128 Street for retail-commercial development by way of an OCP re-designation, which would allow for the rezoning of the lots in the area to permit commercial uses. Such rezoning would be considered on the basis of some conditions that would need to be satisfied by the respective land owners/developers. The area would be enhanced and promoted as a unique cultural destination. Commercial uses on "Industrial"-designated lands outside of the defined precinct would not be supported.

Pros:

- A "levelling of the playing field" would result by way of the conditions that would need to be satisfied by the commercial-use developers in the area through the commercial rezoning process that would include paying commercial DCC rates similar to other parts of the City;
- An opportunity would exist to create a vibrant cultural commercial area to the benefit of the Newton area and the City as a whole;
- The conditions that would need to be satisfied in relation to the commercial-use rezoning process would include aesthetic considerations such as building design and landscaping that would be enhance the area, create a sense of place and improve the pedestrian experience of the area;
- Transportation infrastructure including both access and parking would be provided to the commercial developments in a manner that would support the reasonable operation of the area; and
- Industrial lands in Newton outside of the defined precinct would be guarded against further commercial intrusion.

Cons:

- The City would experience some loss of its industrial land base but this loss would be mitigated by the fact that it would be replaced with commercial uses that also generate jobs in the local economy.
- The lands redesignated for commercial uses would need to be carefully buffered from adjacent industrial uses so as to minimize potential nuisance due to adjacency.

Result of Evaluation of Options:

Based on the above evaluation, staff holds the view that Option 2 "Develop a Commercial Precinct" will yield the best results for the City over time and therefore it is the recommended approach.

Proposed Boundary of the Commercial Precinct

Based on a study the properties in the subject area of 128 Street in relation to where commercial uses would be best integrated, staff has concluded that the area illustrated in Appendix I would be an appropriate area for a the commercial precinct, i.e., the Central Newton Cultural Commercial District.

The proposed precinct is centered on the intersection of 128 Street and 80 Avenue and has an area of approximately 16 hectares (40 acres). It is composed of three major "anchor" sites, the existing Payal Centre to the northeast of this intersection, the York Centre at the southeast corner of the intersection and the site on which the Punjab Cloth House development is located in the northwest corner of the intersection. The properties in the immediate northeast corner of 128 Street and 80 Avenue currently do not contain commercial development; however, under the approach that is recommended in this report they could be converted to commercial uses in the future.

Subject to Council approval of the recommendations of this report, a more detailed study of the area will be undertaken to establish the range of permitted commercial uses, the road and pedestrian improvements that are necessary, the design guidelines to which new development in the area would be subject, the enhancements that would be necessary to existing developments that would be necessary to ensure that they had the right "commercial fit" and "place-making" elements to promote the area as a ethnic commercial destination.

A public consultation process would be initiated to seek input on these items.

Study to Confirm Commercial Use Potential

GP Rollo & Associates, a land economics consultant, was retained to assess the merits of creating the CNCCD. The consultant was asked to study and comment on the following:

- The potential for more commercial development oriented towards the South Asian community along 128 Street;
- The impacts on the Newton Town Centre and Scott Road areas of additional South-Asian-oriented commercial development along 128 Street; and
- The advantages and disadvantages of expanding commercial businesses along 128 Street, in consideration of the City's Industrial Land Strategy.

The consultant found that South Asian and Fijian households support a large amount of commercial business, located in both traditional commercial areas and more specialized areas such as the 128 Street corridor in Newton. The success of existing retail and service businesses in the study area attests to the strength of this demand. It also speaks to the desire of the South Asian and Fijian communities to shop in a commercial area catering specifically to their needs.

The consultant further stated that expanding commercial development on 128 Street would allow the City to develop an iconic destination commercial area with minimal impact on other commercial centres. The consultant concluded that there is enough demand for additional businesses in the study area to accommodate up to 12 hectares (30 acres) of commercial development or more over the next 15 years. According to the consultant, employment and spin-off benefits that would result from developing a commercial destination in this location will be greater than the employment and benefits from industrial uses in the same area.

Proposed IB-3 Zone

Staff has concluded that it is important to take measures to address the issue of commercial-use encroachment into industrial areas in the City. As discussed earlier in this report, the existing Business Park (IB) Zone allows for retail sales provided that the products being retailed from the lot are manufactured or warehoused on the same lot. This provision in the IB Zone, along with other permitted uses in the IB Zone, such as medical offices, beauty salons, travel agencies and eating establishments, detract from the underlying industrial intention of the IB Zone. Staff has been utilizing CD Zones in place of the IB Zone for many new developments due to concerns with the lots that are zoned as IB being used primarily for commercial uses, which was not the intention for the Zone. The CD Zones are based on the IB Zone but exclude accessory retail uses and limit eating establishments.

In view of the administrative complexities associated with the IB Zone and to eliminate the need to develop individual CD Zones to address the issues, staff are of the view that a new IB-3 Zone should be established.

The proposed IB-3 Zone should reflect the following:

- "Retail commercial" uses would not be permitted but "wholesale uses" would be permitted. A definition of "wholesale" would need to be defined in the Zoning By-law;
- "Professional office" uses (i.e., accountants, doctors, dentists, lawyers, advertising, real estate, advertising) would not be permitted as these are more appropriately located in commercial and town centre areas;
- "Eating establishments" would be limited to coffee shops with a maximum of 35 seats. Larger eating establishments (such as banquet halls) are more suitable to commercial areas. In addition, the design of industrial buildings is compromised if large restaurants/banquet halls are incorporated, due to the height requirements of the eating establishment. Further, the parking requirement for eating establishments is substantially greater than typical industrial uses; and
- "Personal service" uses would not be permitted as these are more appropriately located in commercial areas.

CONCLUSION

Based on the above discussion it is recommended that Council:

- Approve the initiation by staff of a planning process to establish a Central Newton Cultural Commercial District (CNCCD) that will include the following:
 - An Official Community Plan re-designation from "Industrial" to "Commercial" of the area that is outlined on the map, which is attached as Appendix I to this report;
 - The development of design guidelines to ensure that appropriate cultural elements are incorporated into the design and development of sites in the CNCCD with a view to elevating the overall design and architectural quality of the area;
 - The possible establishment of a Business Improvement Area (BIA) for the new commercial district to support its on-going vibrancy;
 - The introduction of a Neighbourhood Concept Plan-type amenity contribution scheme to fund enhancements to the public realm in the CNCCD, which would include enhanced streetscapes, improved pedestrian connectivity and other public amenities; and
 - A public consultation process regarding the above-listed matters; and
- Authorize the City Clerk to bring forward for the required readings an amending by-law to Surrey Zoning Bylaw, 1993, No. 12000 to introduce a new "Business Park 3 (IB-3) Zone" as generally described in this report, which will support and regulate future business park development in the City.

Original signed by
Jean Lamontagne
General Manager,
Planning and Development

MJ:saw

Attachments:

- Appendix I Proposed Central Newton Cultural Commercial District
- Appendix II Property which is the Subject of Development Application No. 7906-0121-00
- Appendix III City Policy No. O-43

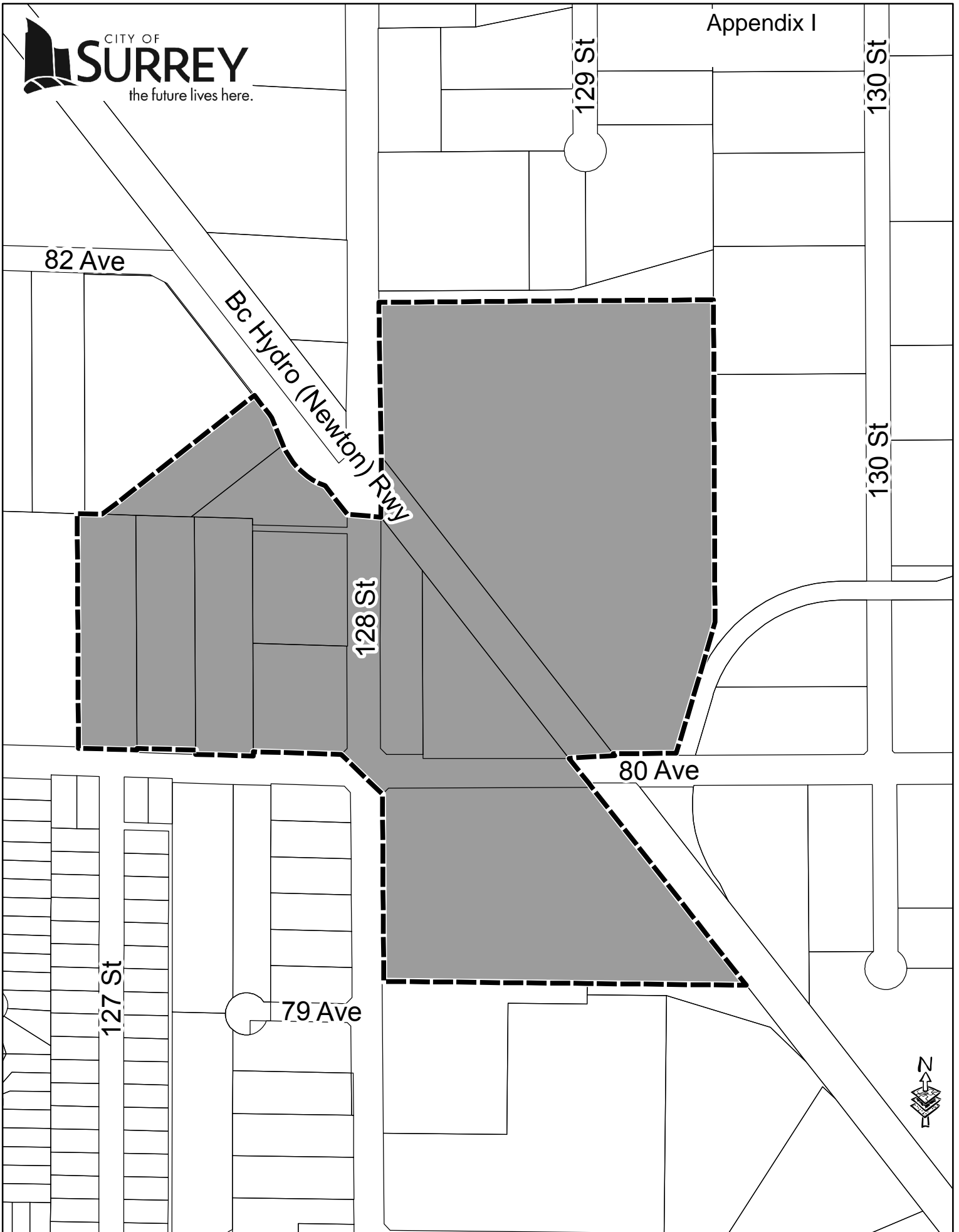

Appendix II
 City of Surrey
 PLANNING & DEVELOPMENT REPORT

File: 7906-0121-00

Planning Report Date: April 12, 2010

PROPOSAL:

- **OCP Amendment** from Industrial to Commercial
- **Land Use Contract** discharge (LUC 150)
- **Rezoning** from CD (By-law No. 14640) and IL to CD (based on IB and C-8 Zones)
- **Development Permit**

in order to allow expansion of an existing industrial development by adding retail commercial and banquet hall uses, in addition to upper storey office and warehouse space.

LOCATION: 12725/43 - 80 Avenue and 8053/63 - 128 Street

OWNER: Vancouver Punjab Cloth House Inc. and 591430 BC Ltd.

ZONING: CD (By-law No. 14640) and IL and LUC 150

OCP DESIGNATION: Industrial

LAP DESIGNATION: General Industrial

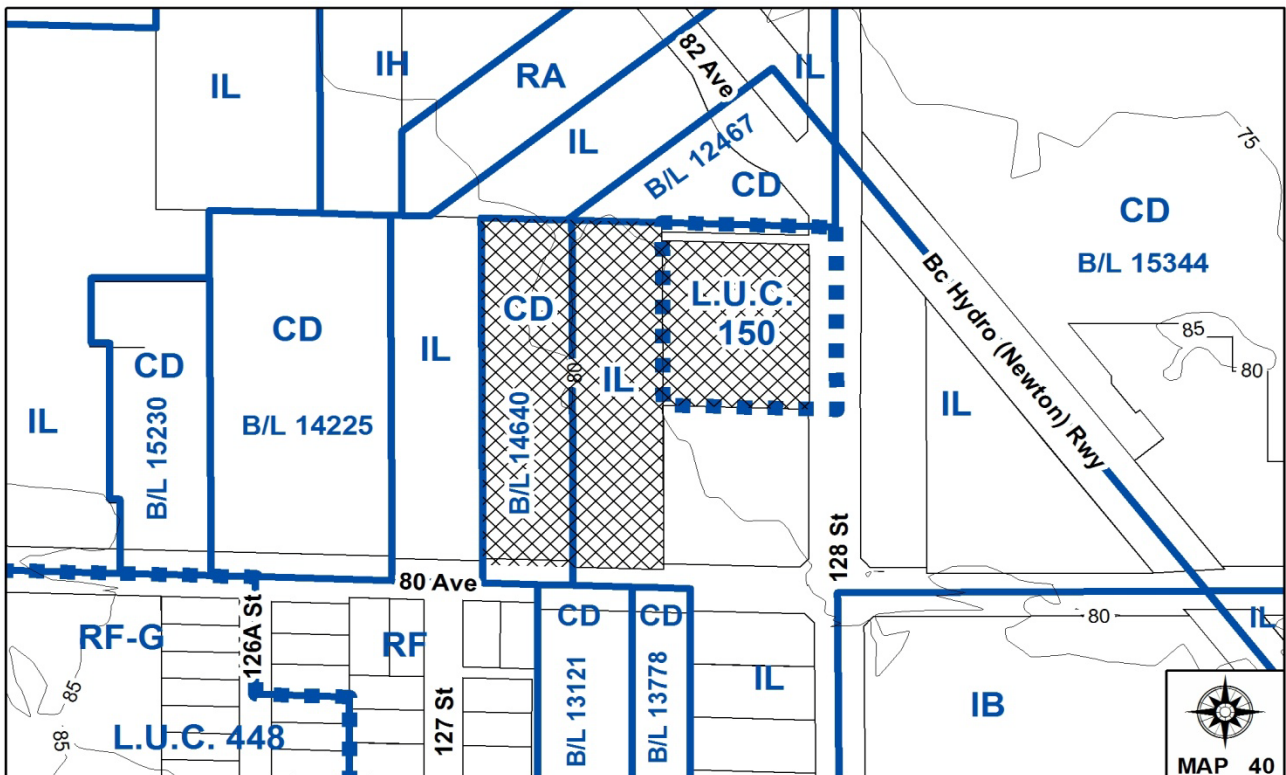
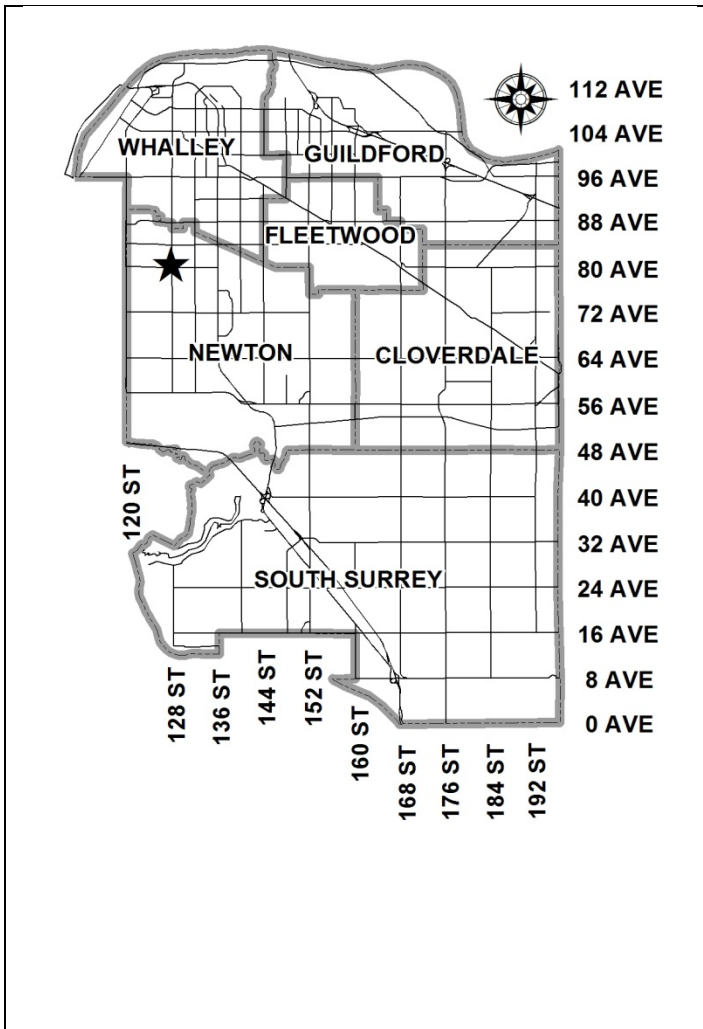



CITY POLICY

No. O-47

REFERENCE:	APPROVED BY:	CITY COUNCIL
REGULAR COUNCIL MINUTES	DATE:	03 FEB 2003 (RES.R03-209)
	HISTORY:	20 OCT 2000 (RES.R00-2575) 13 JULY 1998 (RES.R98-2129)

TITLE: REZONING OF INDUSTRIAL DESIGNATED LANDS IN THE VICINITY OF 84 AVENUE AND 128 STREET

Purpose

The purpose of this policy is to restrict any further rezoning, including rezoning to Comprehensive Development Zone (CD) to permit commercial uses on lands located in the vicinity of 84 Avenue and 128 Street which are designated "Industrial" in the Official Community Plan and thereby to protect these lands for industrial uses.

Policy

As of the date of adoption of this policy, Council will not consider any further applications for rezoning to any commercial, retail and ancillary retail zone or Comprehensive Development Zone (CD) of lands located in the vicinity of the 84 Avenue and 128 Street intersection as outlined on the attached location map which is designated in the Official Community Plan for Industrial use.

Amended October 30, 2000

Removal

The property located at 12905 - 80- Avenue is removed from policy.

* This policy is subject to any specific provisions of the Local Government Act, or other relevant legislation or Union agreement.

REZONING OF INDUSTRIAL DESIGNATED LANDS
IN THE VICINITY OF 84 AVENUE AND 128 STREET

No. O-47(2)

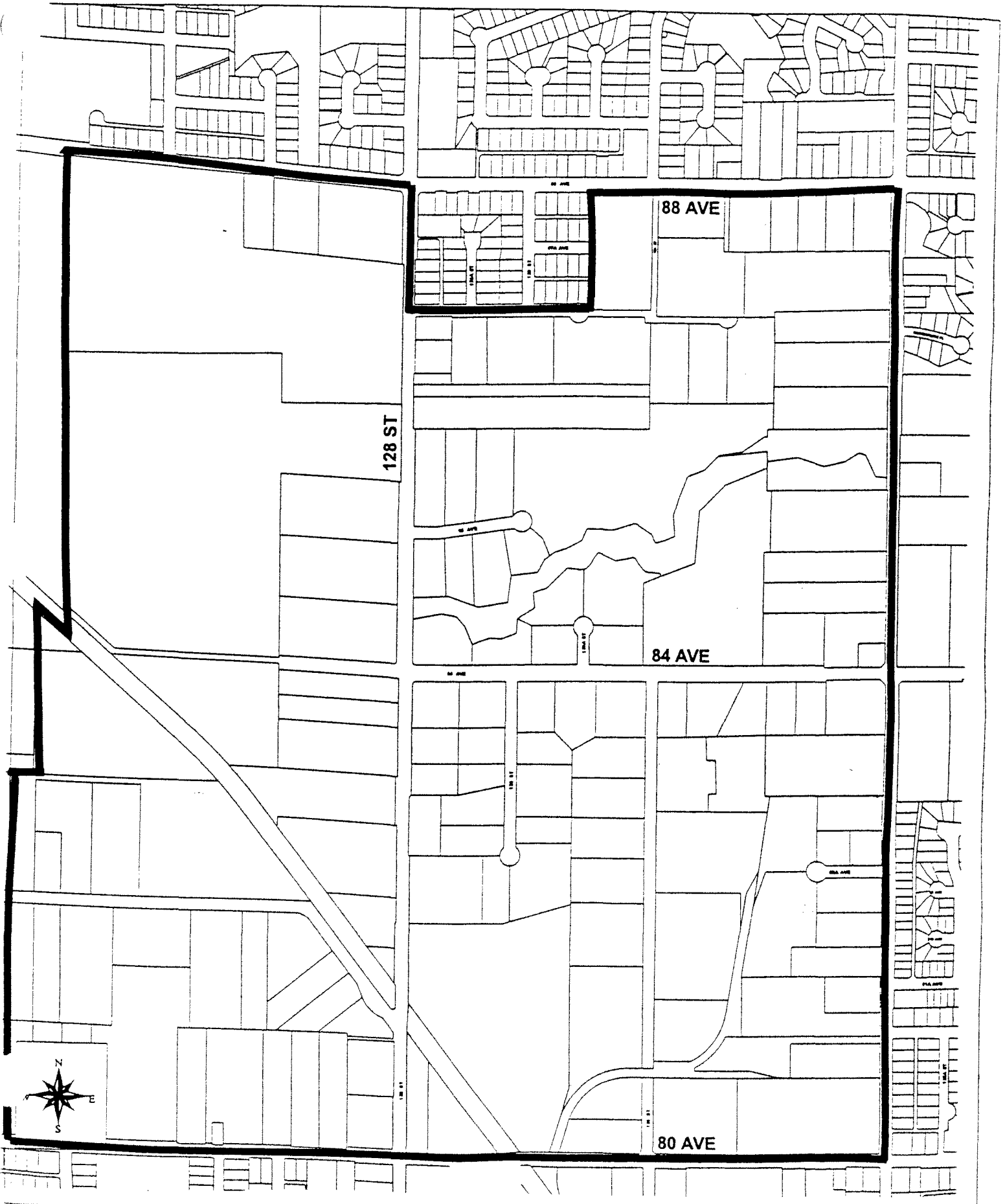

Central Newton Cultural Commercial District Guidelines



LOCATION OF CENTRAL NEWTON CULTURAL COMMERCIAL DISTRICT

The Central Newton Cultural Commercial District (CNCCD) is located at the intersection of 80 Avenue and 128 Street, as shown below.

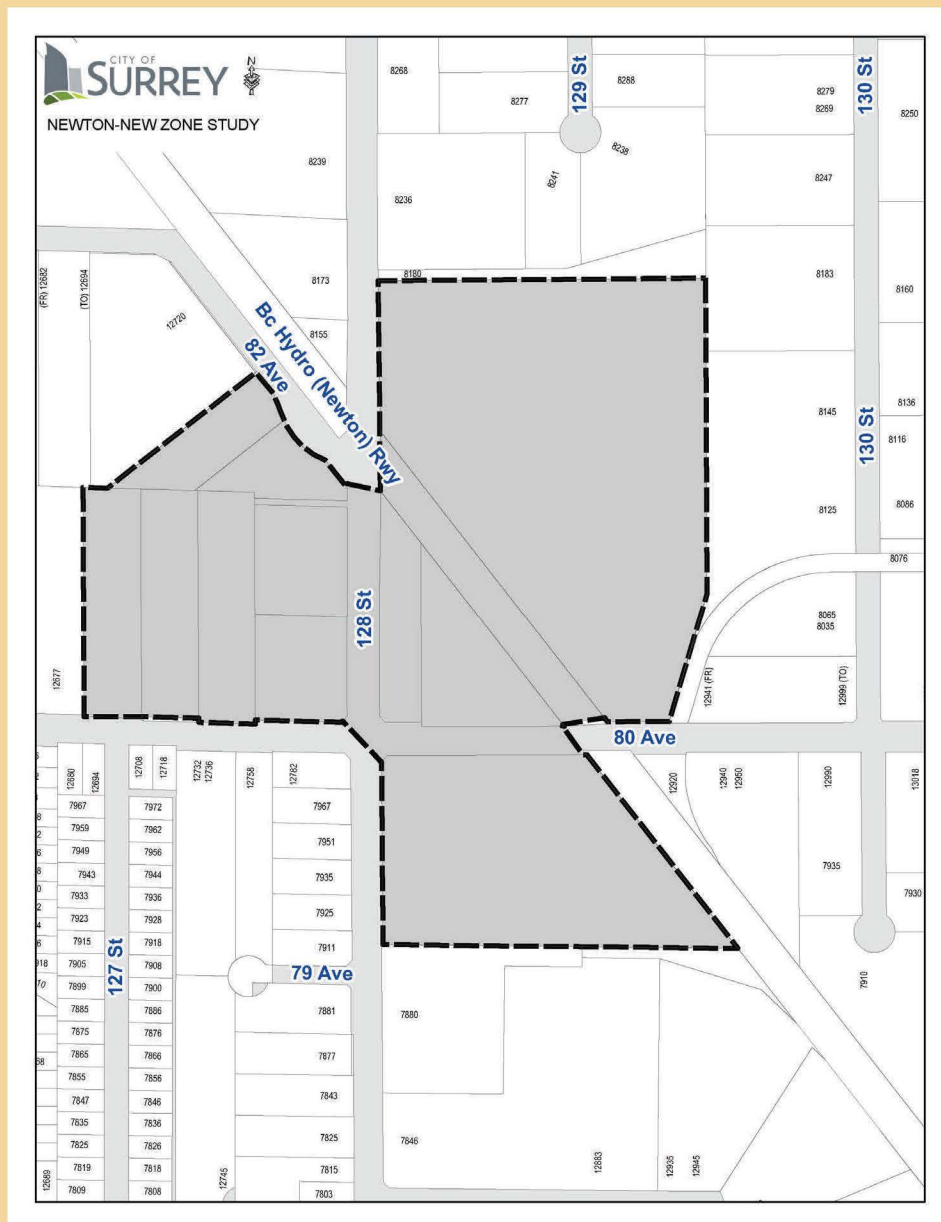

LOCATION OF CENTRAL NEWTON CULTURAL COMMERCIAL DISTRICT – AERIAL PHOTO

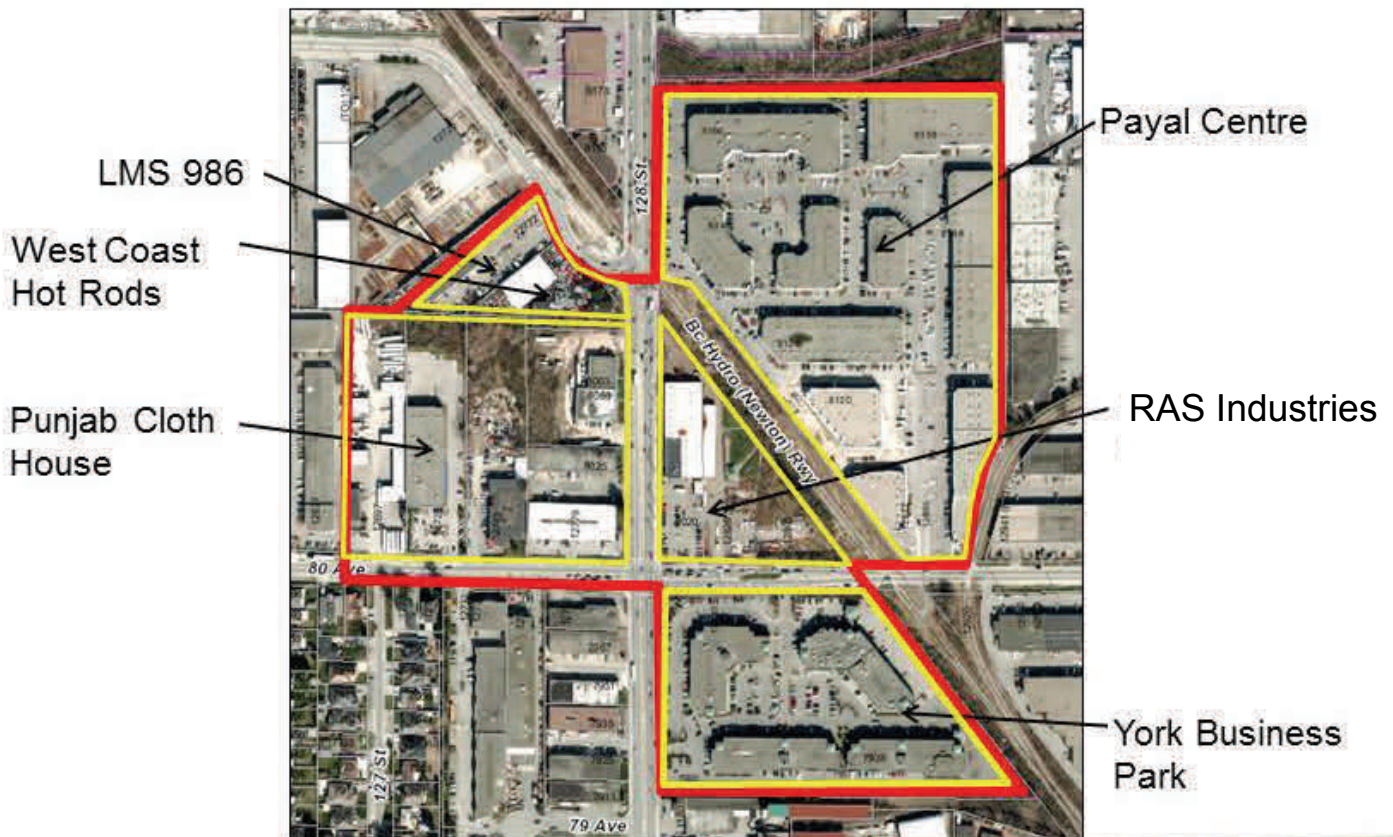

SITE DESIGN

Provide a stormwater management strategy for the site at the early design stages.

Avoid unwatched backwater areas in site planning. Provide surveillance cameras if required.

Locate parking vents away from public views and incorporated into the building or landscaping.

Create a safe and accessible public realm that incorporates CPTED principles.

Consider universal access to facilitate access for physically/visually/disabled throughout the site including open spaces.

Grading

Establish the site grading at the early stages of design.

The setback areas along the streets should follow the sidewalk grades.

Ensure a gradual transition and so that retaining walls are avoided.

Site Circulation

Connect to the public road, lane and sidewalk system to enhance connectivity for all travel modes including vehicles, cyclists and pedestrians.

Provide direct, functional and safe pedestrian pathway system through parking areas such as between building entrances, parked cars and connecting to sidewalks of the abutting streets.

Incorporate a hierarchy of primary and secondary pathway systems.

SITE DESIGN

Site Circulation (continued)

Provide a minimum of 3.0 m sidewalk along primary pedestrian pathway at building frontages of to allow for tree clearances to weather protection overhangs.

Secondary pathways should provide 1.8 m min unobstructed widths to accommodate equipment use such as wheelchairs and strollers used by disabled persons and designed with consideration for use by visually impaired persons.

Locate convenient universal access to buildings from the parking with curb let-downs or other features.

Extend contrasting, durable concrete sidewalk paving treatment where pathways extend through the parking area.

Provide a physical linkage to transit stations and stops.

Provide bicycle parking facilities at grade close to main entrances with weather protection.

Incorporate beautification and amenity features along pedestrian pathway systems such as distinct durable paving, special landscaping with trees, furnishings such as benches, and overhead weather protection.

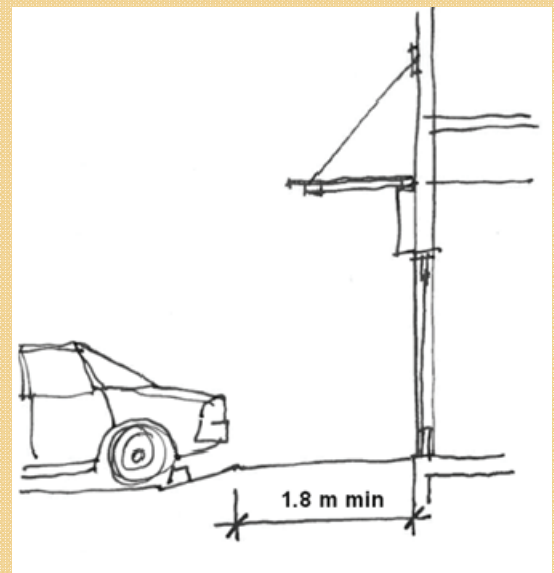
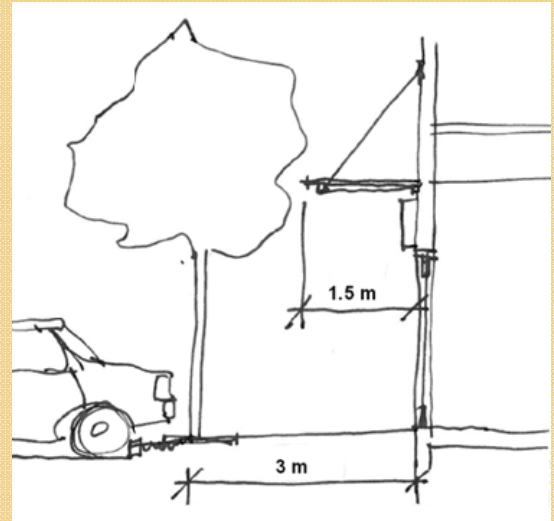

SITE DESIGN

Site Circulation (continued)

Vehicular Circulation

Provide a primary driving route through the site:

- with landscaped boulevards and sidewalks,
- with specialty paving,
- with character lane signage to mimic a public lane
- lined up with driveway on adjacent sites where possible.

Provide joint or shared driveway and ramp access between adjacent developments.

Provide a vehicular connection between adjacent surface parking on neighbouring sites.

Locate driveways for parking off minor streets or lanes rather than streets to retain a safe, walkable streetscape.

Reduce conflicts between heavy vehicles and traffic from visitors and employees.

Locate parking away from street frontages or at street corners.

Divide large surface parking areas into smaller sections defined by a building or a driveway with a sidewalk in landscaped islands on each side.

Locate wheelchair accessible parking spaces close to main building entrances and addressing access to the sidewalk with curb let-downs or other feature.

Locate loading areas away from the public views and public realm interfaces.

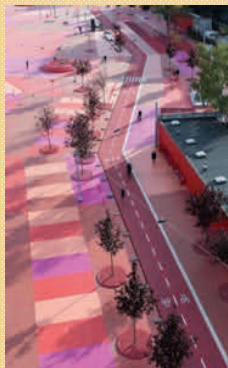

SITE DESIGN

Public Realm and Street Interface

Provide a setback along the streets to incorporate specialty lighting, an inner row of trees in planting beds with walk-throughs and furnishings.

Provide in-ground planting along the street edges and avoiding planter walls and steps.

Furnishings along the streets should be consistent and in character with the area for existing and new development sites.

Lighting along the streets should be consistent and in character with the area along existing and new development sites.

Fencing or gating along the perimeter of the site is not encouraged.

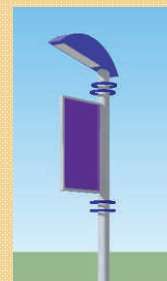
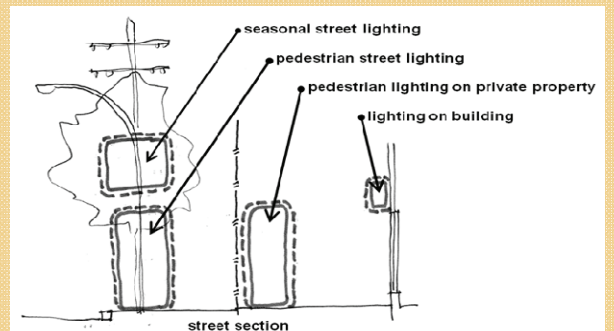
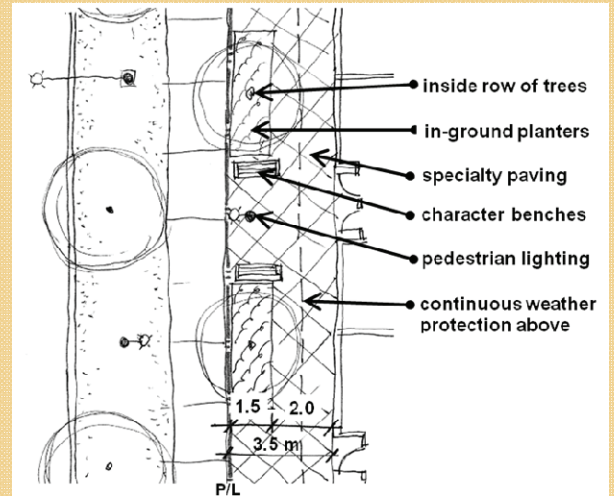

SITE DESIGN

Site Furnishings

Site furnishings to include benches, waste receptacles and bike racks to match the overall character of the development and other site features such as signage and garbage enclosures.

Site Lighting

Providing a hierarchy of different lighting types with a coordinated appearance such as lower scale pedestrian pathways, parking spaces, drive aisles, building and site entrances to larger scale parking lot lighting.

Balance the need for energy efficiency and avoid over lighting.

Using down-lighting and avoid over-spill to any adjacent residential areas.

Coordinate the location of lighting with other landscape elements such as trees.

Locate lighting to assist **visual** surveillance including site security such as cameras.

Site Services

Locate electrical kiosks and gas meters away from the visible public realm and screening.

Locate parking vents away from public views and incorporated into the building or landscaping.

For existing kiosks, vinyl graphic wrap and landscape screening should be provided.

Where garbage cannot be located underground, locating garbage enclosures away from the visible public realm and fully enclosed within a secure structure.

Designing garbage enclosures to be coordinated with the overall design of the development using the same high quality durable materials and with secure gates and a roof.

Site Signage

Provide signage/wayfinding concept plan for overall site orientation. Include concept for site access points.

A consistent design for monument signs should be provided on each site in key locations.



SITE DESIGN

Landscaping

Provide a tree retention plan and arborist report.

Providing a minimum 6 m specialty paved area at each driveway entrance where visible from the public realm using durable materials such as stamped concrete or pavers in character with the area.

Providing curbed landscaped islands throughout the parking area to define parking clusters, visually break up and screen the scale of the parking area, to highlight pedestrian routes, provide trees for shading.

Providing at least 1.5 m radius for tree root balls in islands. Where a 1.5 m radius cannot be provided the minimum landscape strip width should not be less than 1 m for protection from vehicles with structural soil surrounding the tree under paving.

Incorporating design features to avoid damage to landscape and tree trunks from vehicles.

Maximizing tree spacing appropriate to the mature size of the tree species with at least one tree in each island.

Using single stem, deciduous shade trees, 5 cm calliper or larger with canopies that begin no less than 2 m

above grade.

Providing mix of #1, #2 and #5 pot size shrubs within islands in addition to trees with some evergreen or other plant material for year round interest.

Locating trees no closer than 2 m from face of building, building foundation or retaining wall. Using only small growing species within 3 m, medium growing species within 4 m and where large growing trees are proposed, locating no less than 4 m from the face of building, building foundation or retaining wall.

Using landscaping to screen blank walls.

Using landscaping and landscape materials to conform to the latest version of the BCSLA/BCLNA "BC Landscape Standard".

SITE DESIGN

Public Open Space

(Refer also to City of Surrey Placemaking and Public Space Guidelines.)

Provide publically accessible open space(s) on the site.

Locate in a sunny location, visible to the street with a seamless connection within the guardianship of ground floor commercial or residential guardians.

Provide a variety of program and maximize seating opportunities.

Enhance the open space with night time lighting in character with the overall architectural design.

A plaza which is furnished with a variety of amenity features encourages general public usage and creates a sense of liveliness and excitement. Art work should provide a focal point for the plaza or become an integral component of the overall design of the plaza. Bike racks and waste receptacles are practical, essential amenities.

Open spaces should also take advantage of distant views to the mountains, Mount Baker, Fraser River and other landmarks.

Selection of surface materials should result in easy access for the elderly and disabled, and also discourage incom-

patible plaza activities such as skateboarders. Placement of planters, non-moveable seating and handrails should further encourage easy wheelchair and pedestrian access, and seek to discourage the use of skateboards.

BUILDING FORM, CHARACTER AND MATERIALS

Building Form and Layout

Continue the predominant building form in the area as simplified industrial forms but emphasize individual, vertical expression reflecting 'small shop' frontages.

Height could be a maximum of 4 storeys or 16m height.

Locate buildings along the street to create a retail walking environments along the public streets.

Create building forms along the streets to create a strong street enclosure particularly at corners.

Locate higher building forms along streets and at corners.

Visually scale down the length of the buildings with vertical articulation by stepping down the roof forms and articulating the façade.

Any ancillary or secondary buildings should be designed to the same architectural level as the principal buildings.

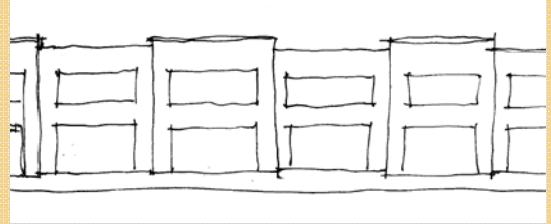

BUILDING FORM, CHARACTER AND MATERIALS

Building Ground Plane Interface

Step the ground floor levels to match adjacent sidewalk grades on sloping sites.

Maximize the number of individual entrances from the street and public areas to create the image of small shop frontages.

Locate active uses facing streets and non-active uses away from the streets to avoid blank walls facing the public realm.

Set main building entrances at the sidewalk grade without the need for transitions such as steps or ramps. Steps and ramps can be incorporated inside the main entrance lobby.

Incorporate lighting on the building to enhance entrances, adjacent streets and public spaces for pedestrians.

Provide continuous, architecturally integrated weather protection over public interfaces including sidewalks, public open spaces, along building frontages and at building entrances. Material such as glass and metal should be considered.

Provide deeper weather protection adjacent to transit stops and main building entrances.

Emphasize main entrances to second floor uses such as banquet halls with canopies and lighting features.



BUILDING FORM, CHARACTER AND MATERIALS

Architectural Character and Materials

Character should read as simple, contemporary, high quality building and materiality as the backdrop with colour and decoration added.

Use durable materials which address weathering and maintenance issues.

Work with the material to enhance the architectural concept such as concrete reveals, textures and variations.

Express the different functions of the building such as entrances as distinct forms by varying the parapet heights and stepping forms.

Engage the second floor to pedestrians by having active uses visible such as windows at restaurant seating, commercial displays and opening doors with balcony railings.

Create the image of narrow individual buildings by differentiating with colours.

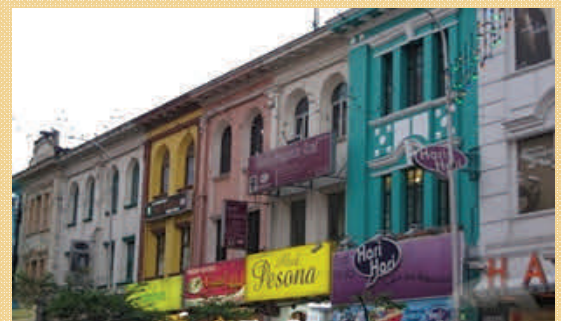
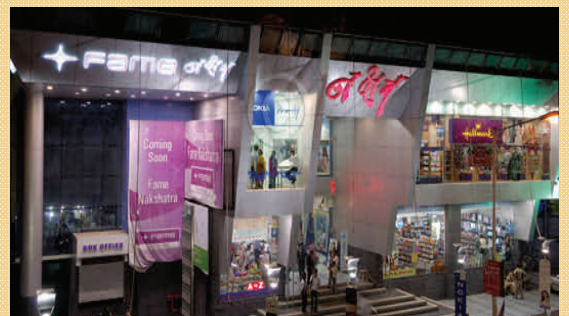

BUILDING FORM, CHARACTER AND MATERIALS

Architectural Character and Materials (continued)

Enhance the character of simplified industrial type buildings by adding decoration to the facades and emphasizing individuality.

Garage door storefronts are encouraged.

Design fully developed street-facing facades on corner sites.

Use materials such as extensive use of glass (transparent and spandrel) which offset the solid nature of the buildings.

Express vertical circulation such as stairs and atria as an architectural element.

Design any visible side walls with visual interest by using such features as texture, colours, graphics, wall art and lighting.

Consolidate roof mechanical units into areas and screening from views.

Treat roof mechanical for acoustics where located adjacent to residential uses.

The building design should embrace sustainable design principles to promote environmentally sensitive solutions including passive solar, (re-)use of materials.

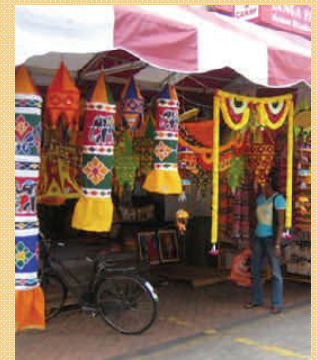

BUILDING FORM, CHARACTER AND MATERIALS

Building Signage

Individually illuminated channel type letters including internally illuminated or back-lighted solid letters are supported and should not exceed 60 cm. (2 feet) in height.

Figurative graphics are encouraged and are effective means of communicating with the passersby.

Blade signs are encouraged.

The minimum vertical clearance for signage (and canopies) should be 2.5m.

High quality logo signage or channel lettering can be considered on the 2nd floor fascia.



OFF-SITE BOULEVARD IMPROVEMENTS & FUNDING FORMULA

City Boulevard Improvements

The proposed off-site boulevard improvements include relocation of sidewalk, new strip of planting and street trees, and new pedestrian lighting. The estimated value of off-site boulevard improvements along 128 Street and 80 Avenue is approximately \$1.2M (2013 estimate).

Payal Business Centre and York Business Centre will be required to contribute to the off-site boulevard improvements in the CNCCD when the sites are rezoned to commercial.

The funding formula is for Payal Business Centre and York Business Centre to share the off-site boulevard improvement cost on a per acre basis. Payal Business Centre is 18.4 acres in area and York Business Centre is 9.0 acres. Therefore Payal Business Centre would be responsible for contributing 67% of the cost and York Business Centre is responsible for the remaining 33% of the cost.

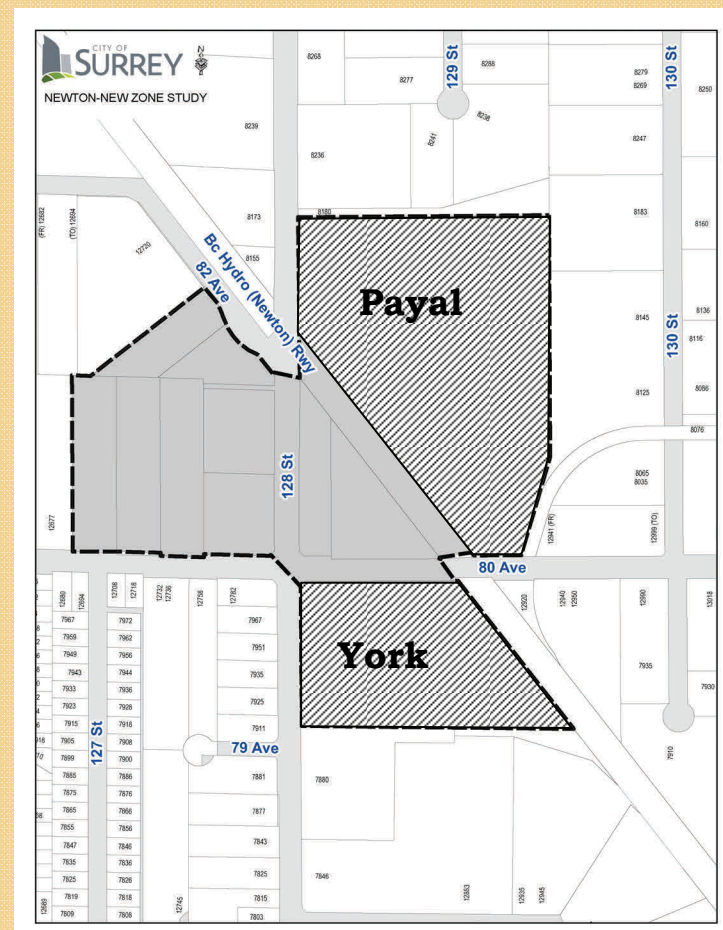
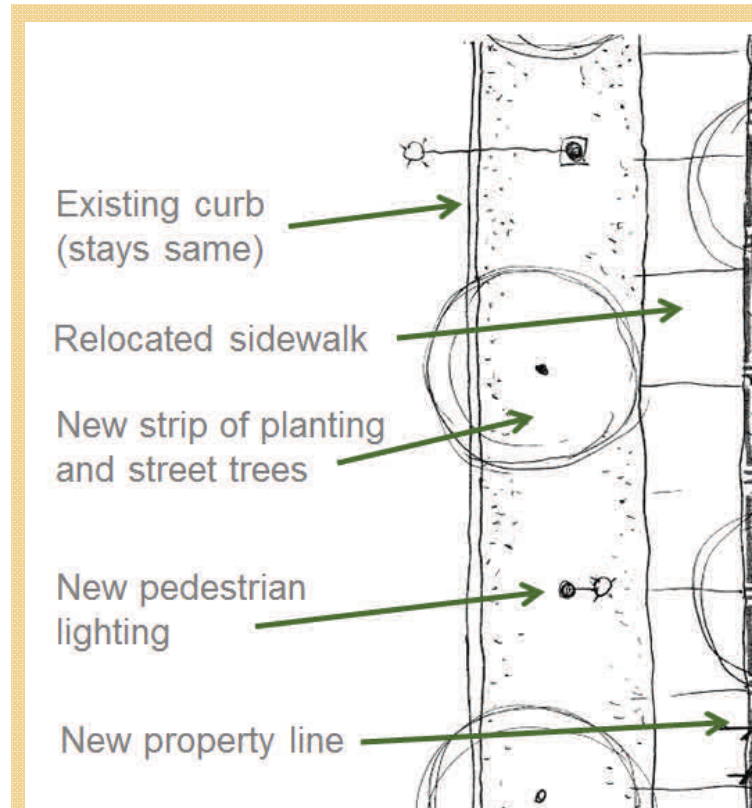

LOCATION OF OFF-SITE BOULEVARD IMPROVEMENTS

The off-site boulevard improvements are proposed along 128 Street and 80 Avenue, as shown below.

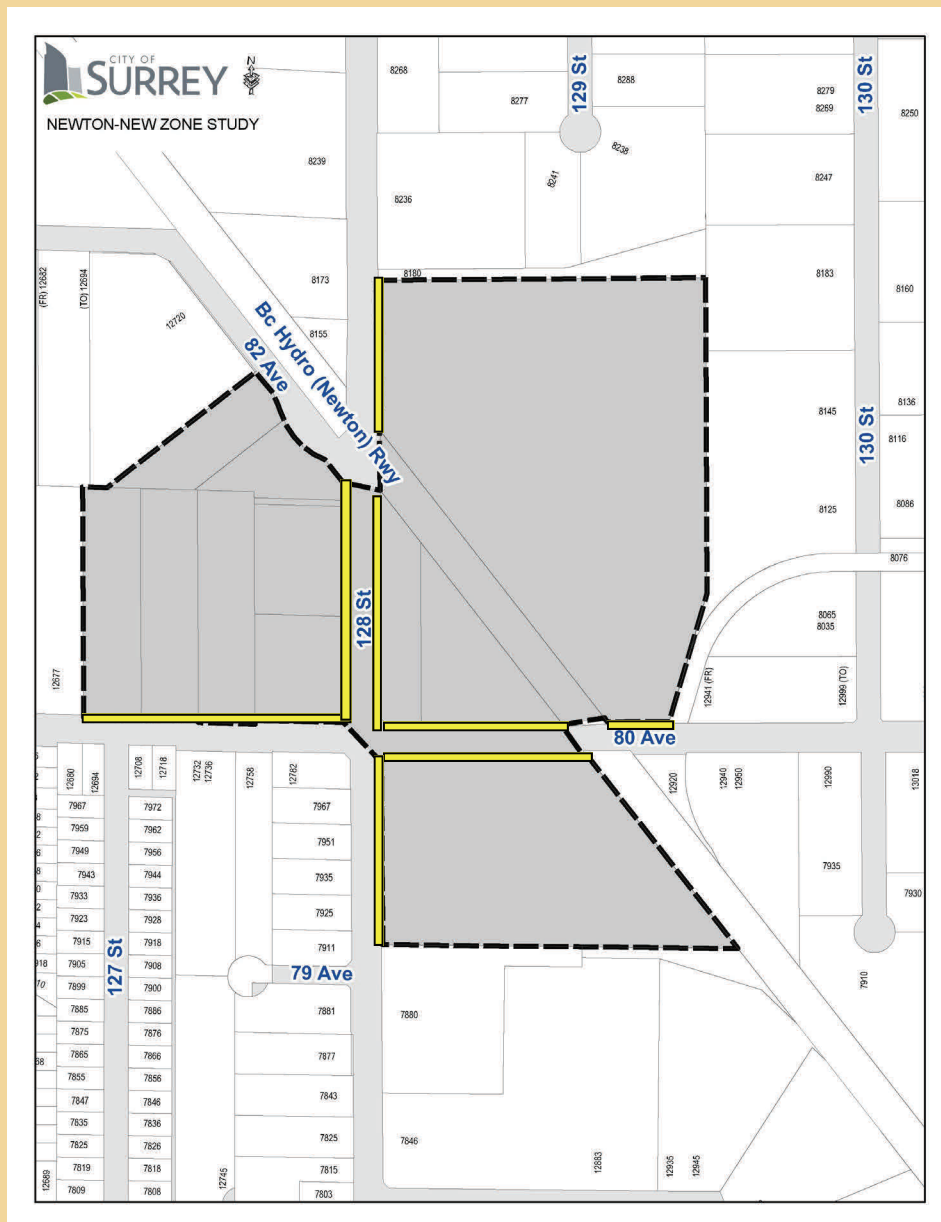



Advisory Design Panel Minutes

PRC₁
 City Hall
 14245 - 56 Avenue
 Surrey, B.C.
THURSDAY, SEPTEMBER 26, 2013
 Time: 4:00 pm

Present:

Chair - L. Mickelson

Panel Members:

J. Makepeace
 T. Bunting
 S. Vincent
 N. Baldwin
 M. Searle
 E. Mashig

Guests:

Sylvan Boulanger, Boldwing Continuum Architects Inc.
 Meredith Mitchell, M2 Landscape Architecture Ltd.
 Jit Sangha, Realco Holdings Ltd.
 Jason Kopodic, Triton Ventures Corp
 Maciej Dembek, Barnett Dembek Architect Inc.
 Lance Barnett, Barnett Dembek Architect Inc.
 Jesse Arora, DF Architects
 Robert Isaac-Renton, Isaac-Renton Architect Inc.
 Patricia Campbell, PMG Landscape Architects
 Bert Everett, Cherington Intercare Inc.

Staff Present:

M. Rondeau, Acting City Architect - Planning & Development
 H. Bello, Senior Planner - Planning & Development
 H. Dmytriw, Legislative Services

ANNOUNCEMENT: a new member, Erika Mashig, Hapa Collaborative, Landscape Architecture & Environmental Design, was introduced.

NEW SUBMISSION**3. 5:45pm**

File No.:	7913-0047-00
New or Resubmit:	New
Last Submission Date:	n/a
Description:	Proposed RZ and DP to allow 6 - one and two storey commercial buildings including a drive-through restaurant
Address:	8020 – 128 St & 12899 – 80 Avenue Central Newton Cultural Commercial District
Developer:	Oleg Verbenkov, Pacific Land Group
Architect:	Jessie Arora, DF Architecture Inc.
Landscape Architect:	Meredith Mitchell, M2 Landscape Architecture
Planner:	Keith Broersma
Urban Design Planner:	Hernan Bello

The **Urban Design Planner** presented an overview of the proposed project and highlighted the following:

- Newton cultural area design guidelines were reviewed by the Panel previously.
- The proposal generally meets the intent of the policies and staff had no specific issues.

The Project Architect presented an overview of the site plan, building plans, elevations, cross sections, and streetscapes and highlighted the following:

- The long building form was articulated. Canopies on upper and lower level will also provide solar protection. Glass awnings for character and weather protection. Elevation materials are of local material: cedar siding, cedar soffits, stone veneer.
- Setback along streets as double walkway with low plantings, paved areas for seating, ornamental lighting.
- Central drive aisle to be patterned concrete with pedestrian walkway along periphery and through building.
- 2 breezeways are proposed to allow connection from the parking to the streets.
- Tilt-up building to match typology of the area but with character added mostly with colour, glass awnings on ground floor, metal awnings on upper floor.
- Sustainable features included LED lighting, pervious materials for landscape, storm water management and planting beds between parking, high efficiency irrigation system, drought tolerant plantings and native plants, low volatile organic compounds (VOCs) products, e.g. carpets, operable windows.

The Landscape Architect reviewed the landscape plans and highlighted the following:

- Central spine to be pedestrian friendly and have a colourful paving pattern with thermo plastic imprint that glows white.
- Water feature on south west left corner entry. Painted metal benches.
- On back of buildings facing right of way - green wall trellis with random geometric pattern.

ADVISORY DESIGN PANEL STATEMENT OF REVIEW

**Proposed RZ and DP to allow 5 - one and two storey commercial buildings
8020 – 128 St & 12899 – 80 Avenue**

Central Newton Cultural Commercial District

File No. 7913-0047-00

It was

Moved by N. Baldwin

Seconded by T. Bunting

That the Advisory Design Panel (ADP)

recommends that the applicant address the following recommendations and revise and resubmit to the Planning staff.

Carried

STATEMENT OF REVIEW COMMENTS

General comments

- Parking on the streets would assist the viability of this shopping area and bring pedestrians to the street – suggest staff further investigate allowing parking on arterials (could be at non-peak times).
 - *Noted*
- Package and presentation well done and organized.
 - *Noted*

Site

- Site planning done well.
 - *Noted*
- Double sided retail will be a challenge.
 - *As per client and marketing team, retail unite opening towards the street and parking is more suitable*
- Like variety of the facades and the linear landscape, double sidewalks.
 - *Noted*
- No public open space proposed. Punctuate linear sidewalk with nodes especially at the breezeways, the corner and facing the sun.
 - *Noted. As per our discussion with the city we shall be introducing larger glass awnings to the breeze way and office entrance lobby. Introduction of big square landscape node in front of these entrances to punctuate entrance.*
- Add social space; potential for large market or festival space.
 - *Noted. Will try and implement this but due to the parking constraints might not be possible.*
- Caution with internal street – good opportunity for doing it well. Paving pattern proposed won't stand up. Colour should be embedded in concrete pavers, laid out in a pattern that tells a story. Sidewalks lined with trees both sides of internal street would be better.
 - *Noted. Will be introducing a mixture of asphalt and colored stamped concrete along the feature driveway.*
- Like idea of repetitive lights along street but keep it consistent as there is already a lot going on with building colours.
 - *Noted. As discussed with the City we shall be providing benches in alternative bays limiting the number to 13 along 128 St. and 13 along 80 Ave.*

- Caution against too many colours for lighting/furniture.
 - *This complex is designed based on the Central Newton Cultural District Zoning and the colors are chosen based on these guidelines.*

Building Form and Character

- Corner building needs more thought:
 - Corner flying roof could be more refined.
 - *Corner fly roof will be more refined in detail construction / Building Permit drawings in consultation with the structural consultants.*
 - Could step back at the ground level to create more open space on the corner.
 - *Noted*
 - The arcades on the north and east should be as warm and bright as possible.
 - *Noted.*
 - Consider large glazed block carefully, i.e. heat gains and how it looks from inside of second floor space.
 - *Noted. This curtain wall on the south west corner is a combination of clear and spandrel panels and heat gains will not be an issue as the units will be air-conditioned and in this era curtain walls are very common and designed to deal with such heat gains.*
- Like breezeways and lobby. They are very important to scheme and a number of ideas were suggested:
 - More breezeways would be better.
 - Should be more visibly expressed from the street elevations.
 - Should be “exterior” space with gates folding flat in the daytime.
 - Could be wider.
 - Retail fronts facing the breezeways could have windows.
 - *As per our discussion with the city we shall be introducing larger awing’s to the breeze ways and also introducing metal ornate gates and windows in breezeway.*
- The colour variety is great and will make this development stand out and help reinforce the cultural identity. The colours should be adjusted slightly, think about daylight and night colours, might be dark at night. Also how the colours will age and be maintained with the pastels.
 - *Noted.*
- The use of local materials (wood especially) could be more complimentary to the tilt-up vocabulary.

- *Noted and specified.*
- Elevator lobby to Building 3 shown oriented only to parking. Consider placing on the south side to serve both street and parking, or use Building 2 elevator and a bridge over driveway to Building 3.
 - *Noted. Most of the office users will be using this elevator from the parking side and we don't think there is a requirement to create another lobby on 128 St.*

Landscaping

- Parking lot could be greener. More and/or bigger trees in parking would be welcome.
 - *Noted. The landscape design will try and incorporate the same in the layout.*

Sustainability

- If possible, increase the amount of permeable surfaces on the site, particularly in the large parking area.
 - *Noted and few intersection pavers will be introduced.*
- The awnings/shading over almost all windows is very good except for southwest corner unit. It will be difficult to heat and cool this unit. Consider using less glass, or vertical solar shades or something similar.
 - *Noted. We will be working on this in more detail during the building permit stage with consultation with the mechanical engineers.*

CPTED

- Important how breezeways work in conjunction with elevators.
 - *Noted.*
- Speeding cars and pedestrian traffic going to drive-thru restaurant - will need traffic calming.
 - *Noted. The drive-thru restaurant has been eliminated in subsequent discussions with the City. Even then we will be taking care of the traffic calming by introducing changes in grades to reduce the overall speed of vehicles.*

Accessibility

- Parking – possibly add one or two more accessible parking spaces.
 - *We have introduced 4 Accessible parks as compared to the required 2 as per Zoning By-laws.*
- Power doors at entrances.

- *Noted. The same shall be specified in our design.*
- Walkways – materials to be accessible for disabled
 - *Noted.*
- Walkways – a minimum of 6' in width.
 - *Noted. We have maintained a minimum width of 7'-0"*
- Elevator buttons panel horizontal.
 - *Noted.*
- Call buttons panel horizontal.
 - *Noted.*
- Washroom wheelchair accessible.
 - *Noted.*

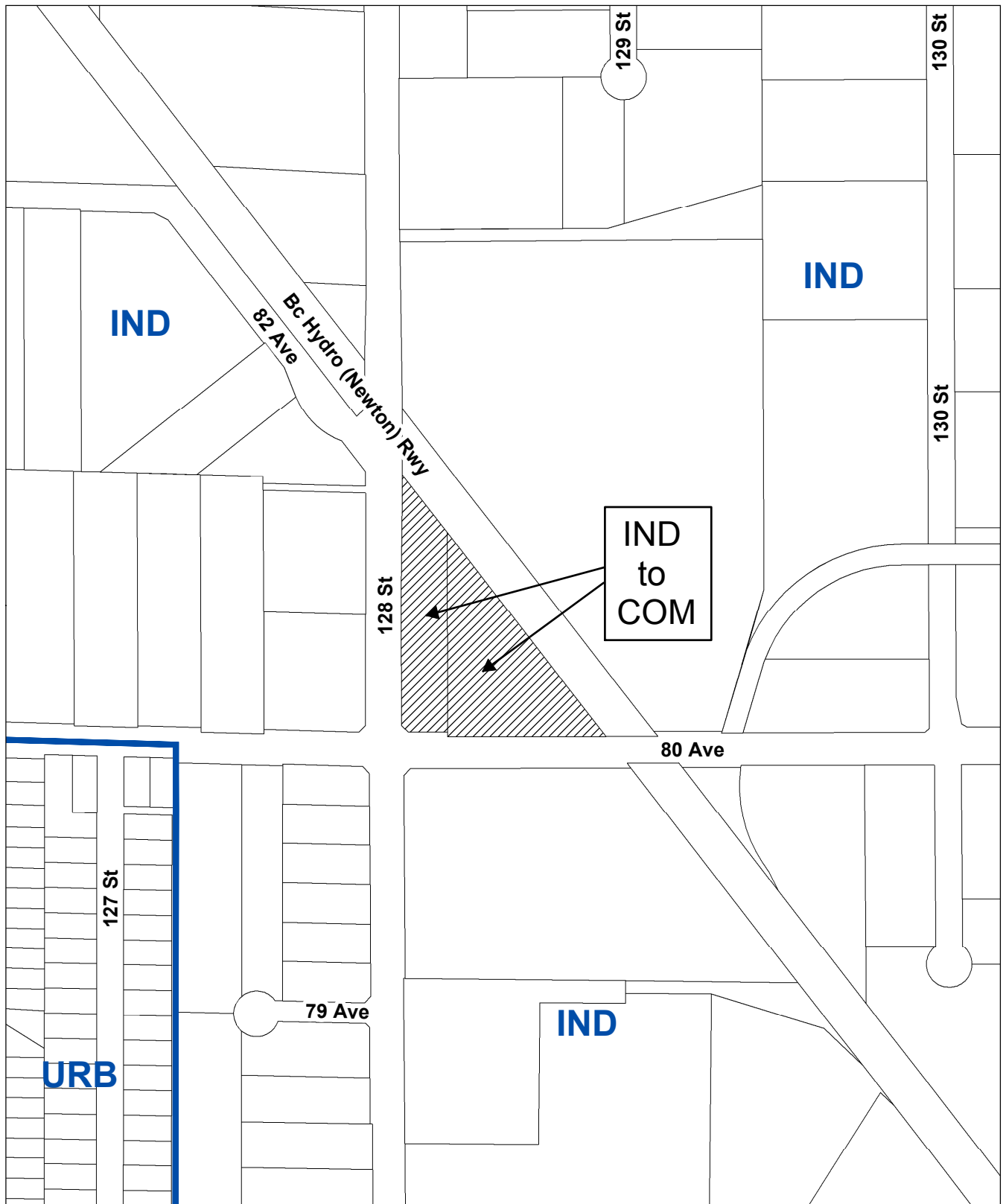

OCP Amendment 7913-0047-00
Proposed amendment from Industrial to
Commercial



CITY OF SURREY

BYLAW NO. _____

A by-law to amend "Surrey Zoning By-law, 1993, No. 12000", as amended
.....

THE CITY COUNCIL of the City of Surrey ENACTS AS FOLLOWS:

- 1. "Surrey Zoning By-law, 1993, No. 12000", as amended, is hereby further amended, pursuant to the provisions of Section 903 of the Local Government Act, R.S.B.C. 1996 c. 323, as amended by changing the classification of the following parcels of land, presently shown upon the maps designated as the Zoning Maps and marked as Schedule "A" of "Surrey Zoning By-law, 1993, No. 12000", as amended as follows:

FROM: LIGHT IMPACT INDUSTRIAL ZONE (IL)

TO: COMPREHENSIVE DEVELOPMENT ZONE (CD)

Parcel Identifier: 000-665-151

Parcel "C" (692019E) Lot 2 Except: Parcel "B" (Reference Plan 13512), South West Quarter Section 29 Township 2 New Westminster District Plan 3270

12829 - 80 Avenue

Parcel Identifier: 001-547-887

Parcel "B" (Reference Plan 13512) Of Lot 2 Except: Part Dedicated Road On Plan LMP42363 South West Quarter Section 29 Township 2 New Westminster District Plan 3270

8020 - 128 Street

(hereinafter referred to as the "*Lands*")

- 2. The following regulations shall apply to the *Lands*:

A. Intent

This Comprehensive Development Zone is intended to accommodate and regulate the development of a community shopping centre serving a community of several neighbourhoods in accordance with a *comprehensive design*.

B. Permitted Uses

The *Lands* and *structures* shall be used for the following uses only, or for a combination of such uses:

1. *Retail stores* excluding *adult entertainment stores* and *secondhand stores* and *pawnshop* provided that the *gross floor area* of each individual business does not exceed 370 square metres [4,000 sq.ft.].
2. *Personal service uses* excluding *body rub parlours*.
3. *General service uses* excluding funeral parlours and *drive-through banks*.
4. *Beverage container return centres* provided that:
 - (a) The use is confined to an enclosed *building* or a part of an enclosed *building*; and
 - (b) The *beverage container return centre* does not exceed a *gross floor area* of 418 sq. metres (4,500 sq.ft.).
5. *Eating establishments* excluding *drive-through restaurants* provided that the *gross floor area* of each individual business does not exceed 150 square metres [1,600 sq.ft.].
6. *Neighbourhood pubs*.
7. *Liquor store* provided that the *gross floor area* of a *liquor store* does not exceed 370 square metres [4,000 sq.ft.]
8. Office uses excluding *social escort services* and *methadone clinics*.
9. *Parking facilities*.
10. *Automotive service uses* of vehicles less than 5,000 kilograms [11,023 lbs] *G.V.W.*
11. *Indoor recreational facilities*.
12. *Entertainment uses* excluding *arcades* and *adult entertainment stores*.
13. *Assembly halls*.
14. *Community services*.
15. *Child care centres*.
16. One *dwelling unit* on the *Lands* provided that the *dwelling unit* is:
 - (a) Contained within the *principal building*; and
 - (b) Occupied by the owner or the owner's employee, for the protection of the businesses permitted on the *lot*.

C. Lot Area

Not applicable to this Zone.

D. Density

The *floor area ratio* shall not exceed 0.80.

E. Lot Coverage

The *lot coverage* shall not exceed 50%.

F. Yards and Setbacks

Buildings and structures shall be sited in accordance with the following minimum setbacks:

Use	Setback	South Yard	West Yard	East Yard
<i>Principal Buildings and Accessory Buildings and Structures</i>		3.0 m.* [10 ft.]	3.4 m.* [11 ft.]	0.0 m. [0.0 ft.]

Measurements to be determined as per Part 1 Definitions of "Surrey Zoning By-law, 1993, No. 12000", as amended.

*Architectural elements, including pilasters, arches and posts are permitted to encroach into the required setbacks to a maximum of 0.6 metre [2 ft.].

G. Height of Buildings

Measurements to be determined as per Part 1 Definitions of "Surrey Zoning By-law, 1993, No. 12000", as amended.

1. Principal buildings: The *building height* shall not exceed 14 metres [46 ft.].
2. Accessory buildings and structures: The *building height* shall not exceed 4.5 metres [15 ft.].

H. Off-Street Parking

1. Refer to Table C.2 of Part 5 Off-Street Parking and Loading/Unloading of "Surrey Zoning By-law, 1993, No. 12000", as amended.
2. *Tandem parking* may be permitted for company fleet vehicles.

I. Landscaping

1. All developed portions of the *lot* not covered by *buildings, structures* or paved areas shall be landscaped including the retention of mature trees. This *landscaping* shall be maintained.
2. Along the developed sides of the *lot* which abut a *highway*, a continuous *landscaping* strip of not less than 1.5 metres [1.5 ft.] in width shall be provided within the *lot*.
3. The boulevard areas of *highways* abutting a *lot* shall be seeded or sodded with grass on the side of the *highway* abutting the *lot*, except at *driveways*.
4. Open display or storage shall be completely screened to a height of at least 2.5 metres [8 ft.] by *buildings* and/or solid decorative fence and/or substantial *landscaping* strips of not less than 1.5 metres [5 ft.] in width. No display or storage of material shall be piled up to a height of 2.5 metres [8 ft.] within 5 metres [16 ft.] of the said screens and in no case shall these materials be piled up to the height of more than 3.5 metres [11.5 ft.].

J. Special Regulations

1. The outdoor storage or display of any goods, materials or supplies is specifically prohibited, notwithstanding any other provision in this Zone.
2. *Child care centres* shall be located on the *lot* such that these centres have direct access to an *open space* and play area within the *lot*.
3. Land and *structures* shall be used for the uses permitted in this Zone only if such uses do not emit noise in excess of 60 dB measured at any point on any boundary of the *lot* on which the use is located.

K. Subdivision

Lots created through subdivision in this Zone shall conform to the following minimum standards:

<i>Lot Size</i>	<i>Lot Width</i>	<i>Lot Depth</i>
10,000 sq. m. [2.5 acres]	30 metres [100 ft.]	30 metres [100 ft.]

Dimensions shall be measured in accordance with Section E.21 of Part 4 General Provisions of "Surrey Zoning By-law, 1993, No. 12000", as amended.

L. Other Regulations

In addition to all statutes, bylaws, orders, regulations or agreements, the following are applicable, however, in the event that there is a conflict with the provisions in

this Comprehensive Development Zone and other provisions in Surrey Zoning By-law, 1993, No. 12000, as amended, the provisions in this Comprehensive Development Zone shall take precedence:

1. Definitions are as set out in Part 1 Definitions of "Surrey Zoning By-law, 1993, No. 12000", as amended.
 2. Prior to any use, the *Lands* must be serviced as set out in Part 2 Uses Limited, of "Surrey Zoning By-law, 1993, No. 12000", as amended and in accordance with the servicing requirements for the C-8 Zone as set forth in the "Surrey Subdivision and Development By-law, 1986, No. 8830", as amended.
 3. General provisions are as set out in Part 4 General Provisions of "Surrey Zoning By-law, 1993, No. 12000", as amended.
 4. Additional off-street parking requirements are as set out in Part 5 Off-Street Parking and Loading/Unloading of "Surrey Zoning By-law, 1993, No. 12000", as amended.
 5. Sign regulations are as set out in "Surrey Sign By-law, 1999, No. 13656", as amended.
 6. Special *building setbacks* are as set out in Part 7 Special Building Setbacks, of "Surrey Zoning By-law, 1993, No. 12000", as amended.
 7. *Building* permits shall be subject to the "Surrey Building Bylaw, 2012, No. 17850", as amended.
 8. *Building* permits shall be subject to "Surrey Development Cost Charge By-law, 2013, No. 17856", as may be amended or replaced from time to time, and the development cost charges shall be based on the C-8 Zone.
 9. Tree regulations are set out in "Surrey Tree Protection By-law, 2006, No. 16100", as amended.
 10. Development permits may be required in accordance with the "Surrey Official Community Plan, 1996, By-law No. 12900", as amended.
 11. Provincial licensing of *child care centres* is regulated by the Community Care and Assisted Living Act R.S.B.C. 2002. c. 75, as amended, and the Regulations pursuant thereto including without limitation B.C. Reg 319/89/213.
 12. Provincial licensing of *neighbourhood pubs* is regulated by the Liquor Control and Licensing Act, R.S.B.C. 1996, Chapter 267, as amended.
3. This By-law shall be cited for all purposes as "Surrey Zoning Bylaw, 1993, No. 12000, Amendment By-law, _____, No. _____."

PASSED FIRST READING on the th day of , 20 .

PASSED SECOND READING on the th day of , 20 .

PUBLIC HEARING HELD thereon on the th day of , 20 .

PASSED THIRD READING on the th day of , 20 .

RECONSIDERED AND FINALLY ADOPTED, signed by the Mayor and Clerk, and sealed with the Corporate Seal on the th day of , 20 .

_____ MAYOR







_____ CLERK

\\file-server1\net-data\csdc\generate\areaproduct\save\30203628005.doc
. 11/20/13 10:11 AM

Metro Vancouver Regional Land Use Designations



Regional Land Use Designations

-  Urban Containment Boundary
-  General Urban
-  Industrial
-  Mixed Employment
-  Rural
-  Conservation & Recreation
-  Agriculture